

MICROPILE QA/QC TESTING USING THERMAL PROFILING

William B. Wright, P.E.¹, Matthew, L. Silveston, P.E.²,
Thomas C. Smoak, III, P.E.³, William L. Snow, Jr., P.E.⁴.

ABSTRACT

With increasing frequency, hollow bar micropiles are being used as a foundation solution along Coastal South Carolina. On a recent project, micropiles were installed using a size 40/20 and 52/26 continuously threaded, hollow core steel bars. The hollow space in the bar allowed an innovative application of Thermal Integrity Profiling (TIP) equipment, normally used for drilled shaft installation verification, to be applied to micropiles. We utilized a single strand of thermal wire sensors inserted into the hollow center bar after completion of micropile installation. A data logger recorded the concrete temperature over a 24 to 36 hour period as heat was generated during the exothermic hydration reaction. Processing software then used the temperatures recorded to generate a 3-dimensional model of the micropile.

The adopted building code in South Carolina is the 2015 IBC, which requires full time inspection of cast-in-place foundations and requires verification of element diameters. Using the known pile length and grout volume, the average pile diameter can be calculated. However, none of the required inspection methods allows direct verification of the pile diameter, which may vary with depth and soil strata.

TIP testing can also detect micropile defects including cave-in or clogged soil cuttings which prevent full grout cover and protection of the steel center bar from corrosion. Even load tests, which are the ultimate proof of capacity, cannot guarantee that defects are not present. While load tests are generally performed on 1% to 2% of the production piles, the ease of TIP testing allows for inspection coverage of 10% to 20%.

While this method of verification cannot replace full time inspection of a qualified inspector or load testing, it can be performed relatively easily, and is another valuable and innovative method to determine proper pile installation.

¹ Senior Consultant, Terracon Consultants, Inc., 1450 5th Street West, North Charleston, SC 29405, 843-884-1234, Bill.Wright@terracon.com

² Senior Principal, Terracon Consultants, Inc., 1450 5th Street West, North Charleston, SC 29405, 843-884-1234, Matt.Silveston@terracon.com

³ Project Engineer, Terracon Consultants, Inc., 1450 5th Street West, North Charleston, SC 29405, 843-884-1234, Thomas.Smoak@terracon.com

⁴ Staff Geotechnical Engineer, Terracon Consultants, Inc., 2201 Rowland Avenue, Savannah, GA 31404, 912-629-4000, wlsnow@terracon.com

INTRODUCTION

Due to the poor soil conditions along coastal South Carolina, hollow bar micropiles are being utilized more frequently. This is especially true in sensitive historical or residential areas where vibrations that are commonly generated during installation of other pile types can be problematic.

As an example, the College of Charleston which is located in the center of the historic district, has all but banned driven piles from being utilized during renovations or on new construction projects on its campus. This is primarily due to issues with vibrations and noise associated with a previous project which occurred in 2010. Another cause for increased micropile use in Charleston is the tight footprint of the increasingly congested city. In many renovations, the construction areas are limited to areas between or inside existing buildings where it is impossible to assemble cranes used to install driven or auger cast piles.

Since micropiles are not used as commonly as other pile types, one drawback to micropiles is the lack of familiarity among some engineers and building code officials. Due to this lack of familiarity, more stringent quality control requirements are sometimes added to the project specifications. It is common to have up to 10 percent of the production piles to have a form of integrity testing performed to verify the integrity of the pile. In auger cast piles, this is accomplished by performing Crosshole or Single Hole Sonic Logging (CSL/SSL) in accordance with ASTM D6760. CSL cannot be performed on most micropiles because the access tube that is used for the test will not have enough grout cover for the test to have accurate results. Thermal Integrity Profiling (TIP) is another technique that can be used to meet the requirements of the specifications which require integrity and dimension verification of production piles.

PROJECT INFORMATION

Terracon was involved in a project where a 3.0 meter (10 feet) tall MSE (Mechanically Stabilized Earth) wall between two split level buildings began showing signs of movement, loss of ground, and failure. This MSE wall was connected to the building foundation walls and would cause structural damage to the adjacent inhabited buildings during failure. A wall repair solution was needed which did not compromise the existing structures.

Complete demolition and rebuild was not practical due to the potential undermining of the adjacent buildings. More common repair techniques were initially explored, and a soil nail repair option was pursued and designed. The soil nail design was bid on by subcontractors. However, due to the arrangement of the buildings and MSE wall, access to the wall was limited and the bids returned from the subcontractors reflected the difficulty of the repair. Due to these higher than expected bids, Terracon was asked to evaluate

other more cost effective options, and developed a buttress-wall design. After evaluating the loading demands of the wall, it was determined that in addition to the buttresses, vertical deep foundations would be needed to reinforce the existing MSE wall. Since the adjacent buildings were occupied and due to the limited space available for equipment, micropiles were chosen as the deep foundation support option.

MICROPILE DESIGN

Structural Design

A hollow bar micropile was chosen for the project which is classified as a Type E micropile in Chapter 10, Section 10.9 of the 2014 LRFD Bridge Design Specifications by American Association of State Highway and Transportation Officials (AASHTO). Since vertical micropiles worked best with the configuration of the wall and existing building, lateral loading was significantly higher than most scenarios where micropiles would be used. Due to these high shear loads, the upper 3.0 meters (10 feet) of the micropiles used steel casing. A combined effort from the structural engineer and geotechnical engineer was needed to determine the required capacities. Ultimately, a micropile with a diameter of 254 millimeters (10 inches) was selected for the project.

Geotechnical Design

We utilized previously obtained Cone Penetration Test (CPT) data near the wall to generate the subsurface profile for geotechnical micropile design. The soil profile consisted of approximately 9.4 meters (31 feet) of interbedded sands and clays over the Cooper Marl Formation. The Cooper Marl Formation is a uniform, well-studied, over-consolidated calcareous clayey to sandy silt which is typically the bearing stratum for deep foundations in the Charleston, SC area. The axial and compressive analysis was performed using the LCPC method (Bustamante and Ganeselli, 1982). The soil layers overlying the Cooper Marl Formation were neglected due to the potential for liquefaction and down drag loads. The available pile capacity is developed from embedment in the Cooper Marl Formation. Due to the small amount of available room and the small number of piles, a factor of safety of 3 was used and a load test was omitted. This resulted in an embedment depth of 13.5 meters (45 feet) below existing grade. Lateral pile software was then used to verify that the lateral deflections of the cased 254 millimeter (10 inch) diameter micropile were within tolerable limits.

MICROPILE QUALITY ASSURANCE/QUALITY CONTROL

The adopted building code in South Carolina is the 2015 IBC, which requires full time inspection of cast-in-place foundations and requires verification of element diameters. Generally, the micropile diameter can be verified by measuring the size of the cutting head used. Since the pile length and cutting head diameter are known, and the grout volume is calculated by counting the number of pump strokes from a calibrated hopper, the average pile diameter can be determined. These methods are reliable and meet the requirements of the IBC, however, none of the required inspection methods allows direct verification of the pile diameter, which may vary with depth and soil strata.

Inspections alone may not entirely satisfy the requirements of the project specifications which may require up to 10% of the piles to be verified by integrity testing. While static load tests or proof tests may be performed, it can be cumbersome and expensive to run load tests on such a high percentage of production piles. Also, since production piles cannot be tested to failure, load tests may not be the most effective verification method. For this project, Terracon performed Thermal Integrity Profiling (TIP) to verify proper micropile installation, as an alternate verification method.

THERMAL INTEGRITY PROFILING (TIP) BACKGROUND

Thermal Integrity Profiling (TIP) is a technique commonly used to verify integrity of drilled shafts. The system uses digital thermocouples assembled on a wire and linked in a series. The thermocouples monitor the temperature of the shaft's concrete as it hydrates. By reviewing the temperature data, the heating and subsequent cooling of the micropile can be reviewed. Analysis of the data is generally performed prior to the peak heat of hydration. Using the known volume of concrete and the shaft's geometry, analysis of the data can provide indications of bulges and necks based on thermal mass of the concrete section. Using software developed by Pile Dynamics, Inc. (PDI), concrete cover and pile radius can be calculated, as well as a 3-dimensional image of the pile can be generated.

A modification of this was used for evaluating micropiles. A single thermal wire was lowered down the annulus of the hollow center bar. The annulus space was water filled to provide a conductive medium for the heat generated by the hydrating grout of the micropile. Since centralizers are attached to the bar at a vertical spacing of 3.0 meters (10 feet), the hollow center bar is assumed to be centered and only one thermal wire is needed for testing. Review of the temperatures will reveal zones of increased heat as well as relatively cooler areas. When combined with grout volumes, the design length and diameter of the pile, the hotter zones can be correlated to bulges. Assuming that the center bar is truly centered, the cooler zones would be interpreted as necks within the pile. However, this assumption of centering is a potential flaw in the approach and if the center bar drifts to one side, the temperatures would appear cooler as it moves away from

the center of the pile. While the pile is assumed to be adequate, a misaligned center bar may be evaluated as a problematic pile. To help overcome this, careful review of the installation logs and monitoring of the pile are crucial.

MICROPILE QA/QC TESTING USING THERMAL PROFILING

We utilized a single strand of sensors inserted into the water filled hollow bar after completion of micropile installation. Since the hollow center of the bar is used to inject grout into the bottom of the micropile, the grout first had to be removed to allow the thermal sensors to be inserted. This was accomplished by inserting a spherical sponge into the top of the hollow bar, and attaching a pump to the top of the rod. The known volume of grout within the hollow core of the rod was exchanged with water by pumping. This allowed the hollow core to be cleared without diluting the structural grout at the bottom of the micropile with water. Of the 12 micropiles tested, we had difficulty clearing the core of 3 micropiles. Figures 1, 2 and 3 are from the installation of one of the micropiles. Once the thermal sensors were inserted, a data logger recorded the grout temperature over a 24 to 36 hour period as heat was generated during the exothermic hydration reaction. Processing software then used the temperatures recorded to generate a plot of temperature versus depth (see Figures 5 & 8), a plot of radius vs. depth (see Figures 6 & 9) and a 3-dimensional model of the micropile (see Figures 7 & 10). These models allow the viewing of variation of the micropile diameter with depth, which could not be accomplished using typical methods discussed in the 2015 IBC.



Figure 1. Viewing down from the top of the adjacent retaining wall, the installation of one of the micro-piles can be seen.



Figure 2. After drilling, the grout is pumped from the center of the bar.



Figure 3. Pumping grout from the center bar of the installed pile.



Figure 4. A cased section is lowered into the drilled and grouted hole. The casing is aligned along the center bar with a series of collars within the casing.

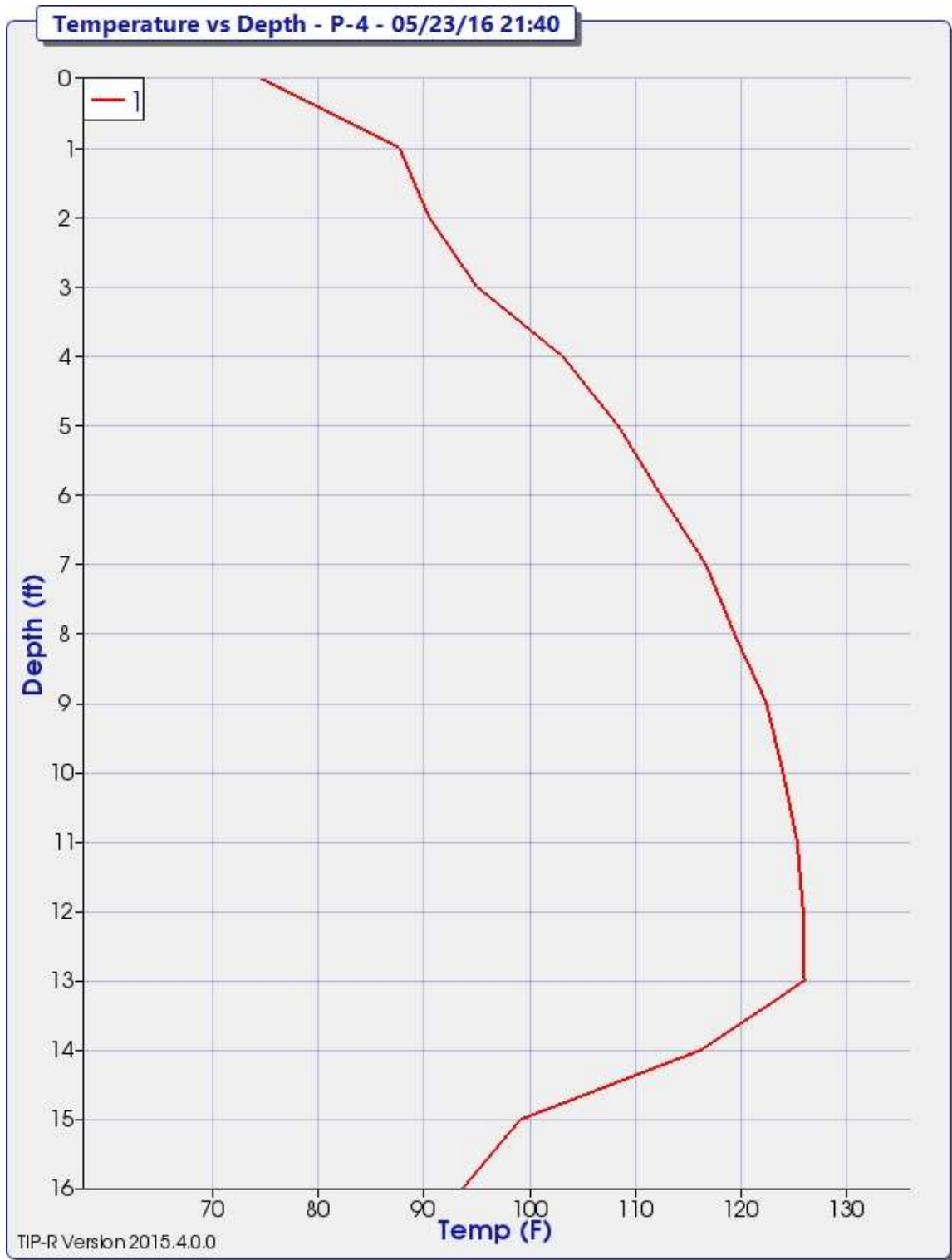

Figure 5. Temperature vs Depth plot for Pile #4.

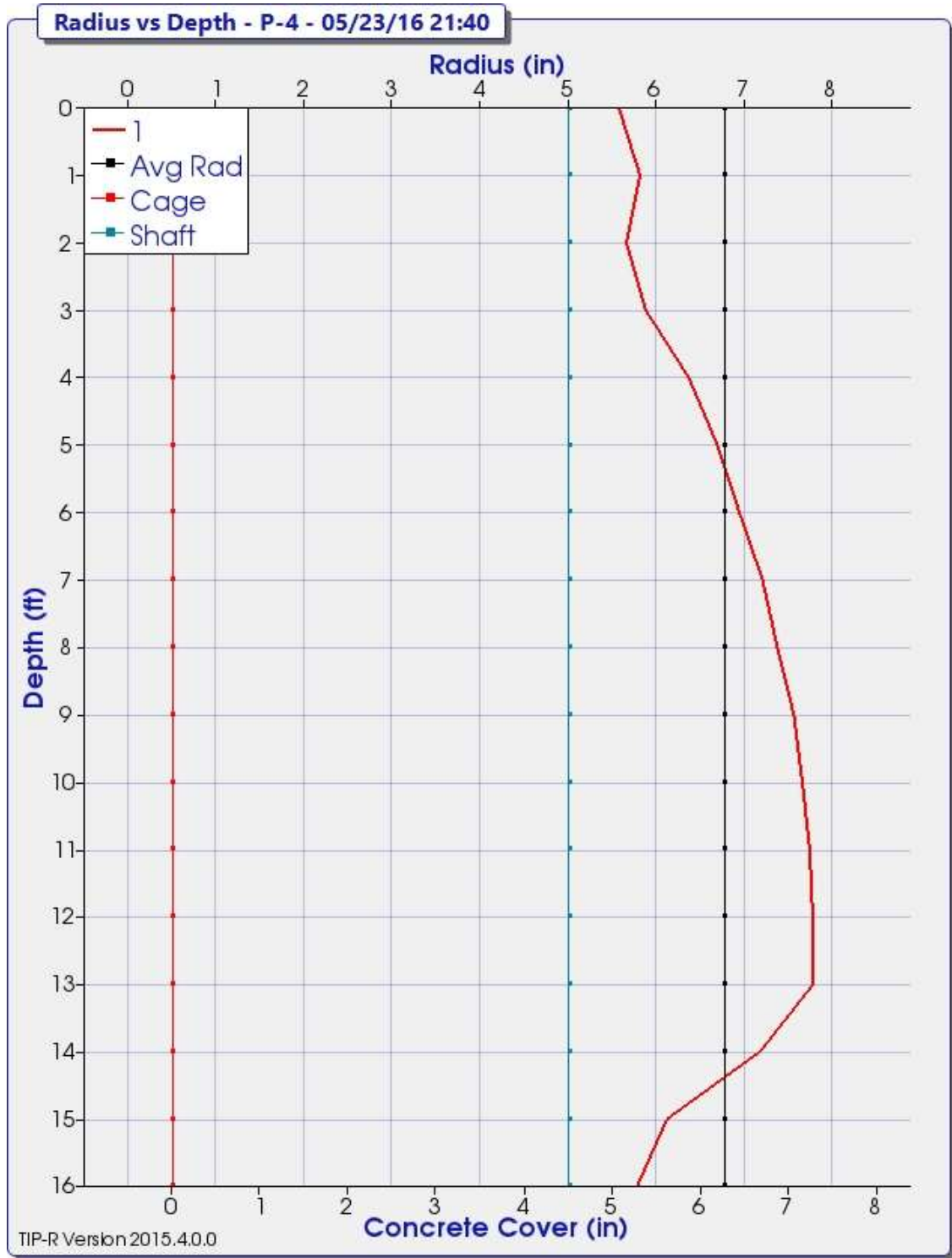

Figure 6. Using the temperature data and measured grout volumes from Pile #4, calculations of the pile's radius can be made. The dashed red vertical line is the center bar, the dashed purple line is the design radius of the pile. The dashed vertical black line is the average radius of the pile. The red line is the calculated radius base on the temperature data.

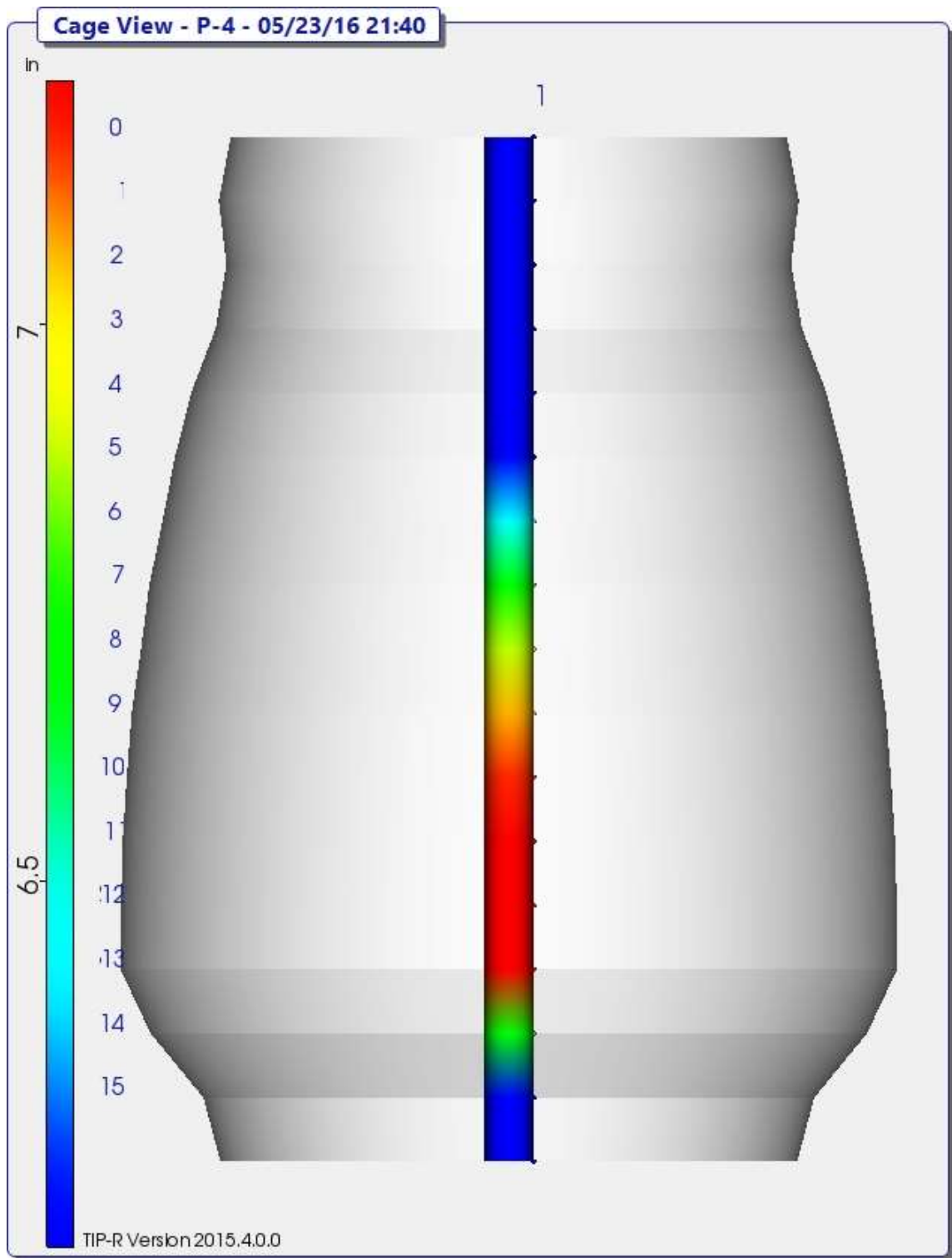

Figure 7. Using the analysis software, a 3D model of Pile #4 can be developed. The center colors correspond to the radius of the pile.

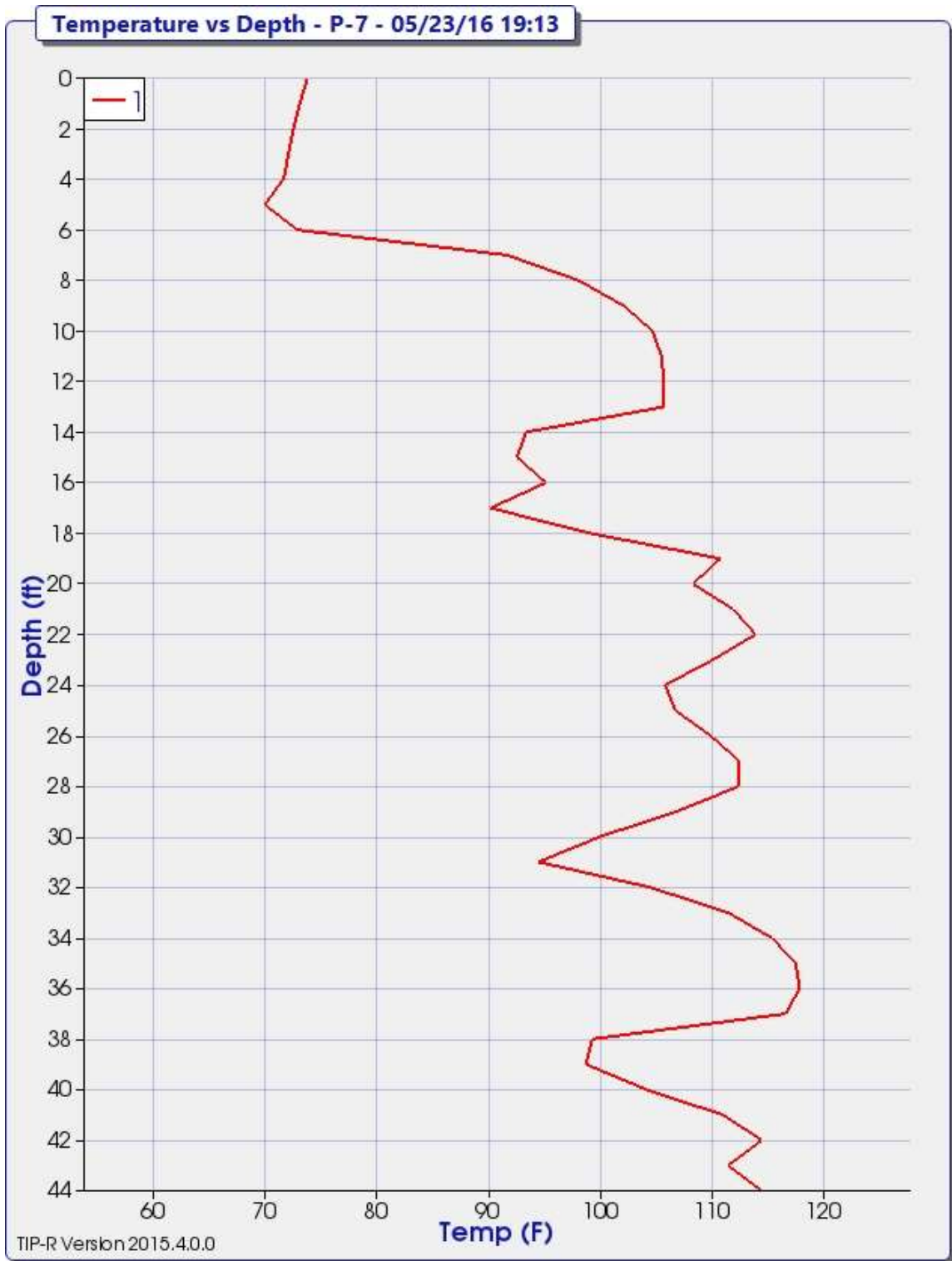

Figure 8. Temperature vs Depth plot for Pile #7.

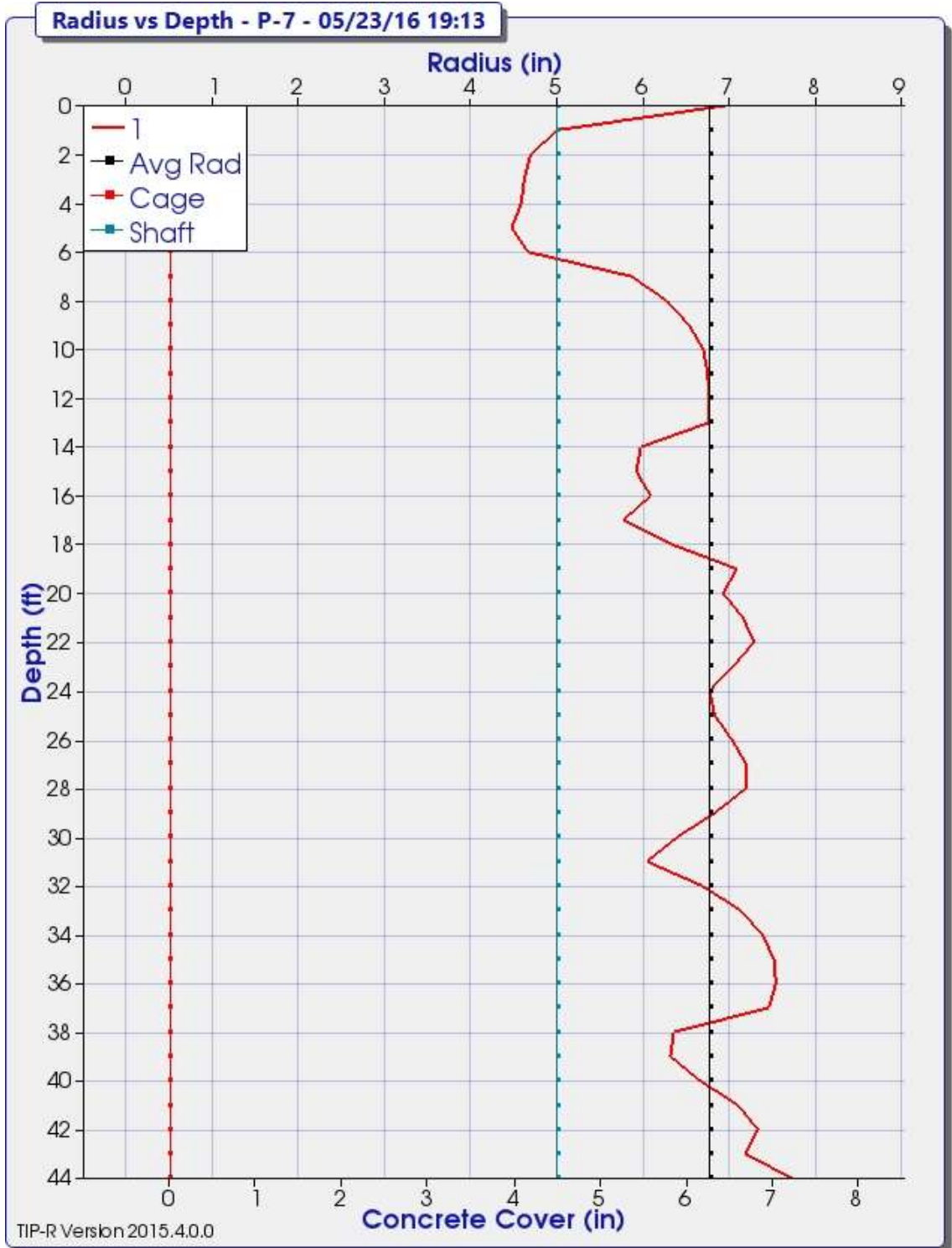

Figure 9. Using the temperature data and measured grout volumes from Pile #7, calculations of the pile’s radius can be made. The dashed red vertical line is the center bar, the dashed purple line is the design radius of the pile. The dashed vertical black line is the average radius of the pile. The red line is the calculated radius base on the temperature data.

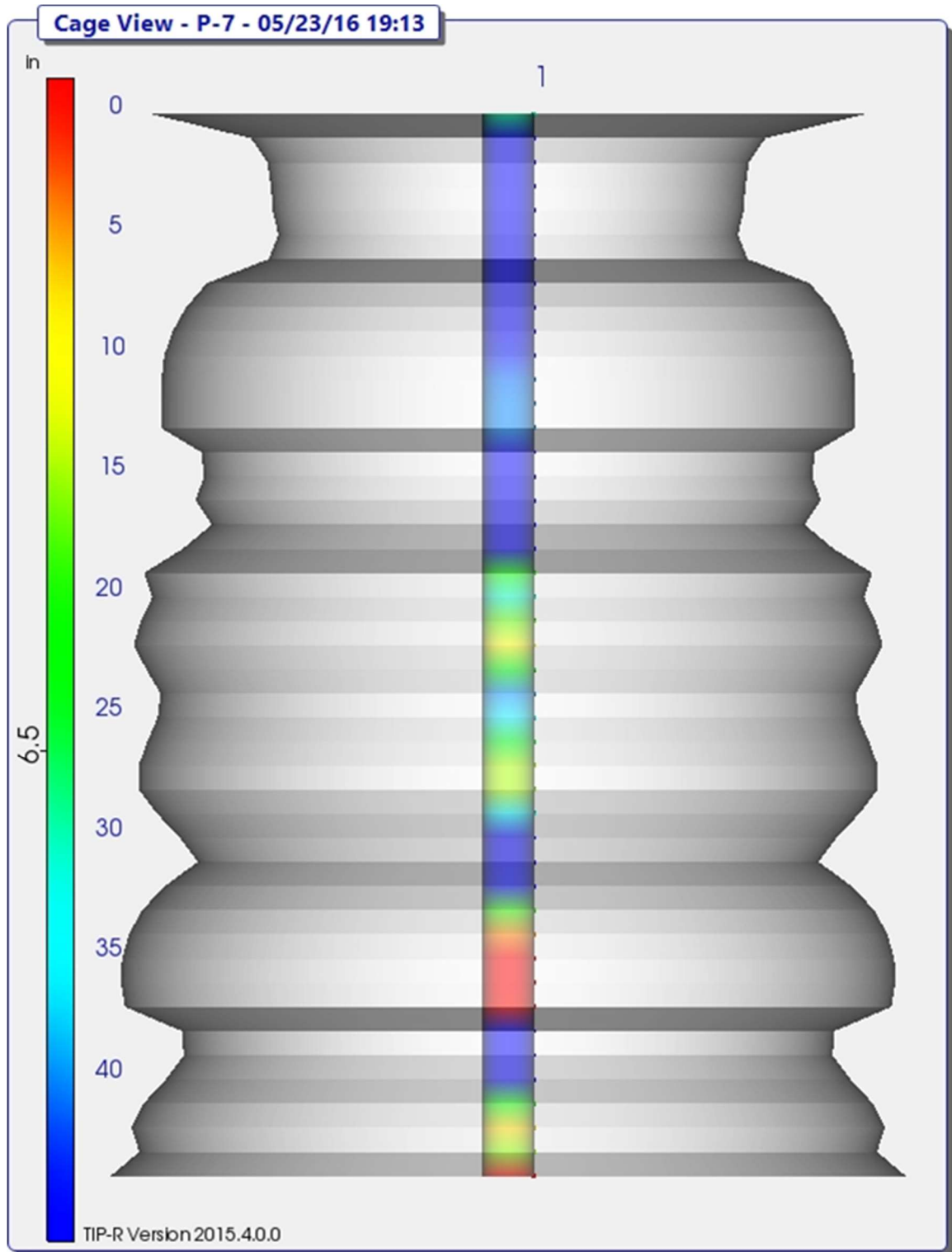

Figure 10. Using the analysis software, a 3D model of Pile #7 can be developed. The center colors correspond to the radius of the pile.

TIP testing can also detect micropile defects including cave-in or clogged soil cuttings which prevent full grout cover and protection of the steel center bar from corrosion. Even load tests, which are the ultimate proof of proper installation, cannot guarantee that defects are not present. While load tests are generally performed on 1% to 2% of the production piles, the TIP inspection method allows for 10% to 20% inspection coverage.

CONCLUSIONS

Table 1 presents the calculated average micropile diameter determined from full-time quality control inspections as compared to the Average micropile diameter determined by TIP testing.

Table 1: Comparison of calculated average micropile diameter vs. average micropile diameter from TIP testing.

Pile No.	Design Diameter mm. (in.)	Embedment Depth m. (ft.)	Grout Volume m ³ (ft ³)	Calculated Average Diameter mm. (in.)	Average Pile Diameter from TIP Testing mm. (in.)
#1	254 (10)	13.5 (45)	1.1 (40)	325 (12.8)	371 (14.6)
#2	254 (10)	13.5 (45)	1.3 (45)	343 (13.5)	345 (13.6)
#3	254 (10)	13.5 (45)	1.3 (45)	343 (13.5)	345 (13.6)
#4	254 (10)	13.5 (45)	1.3 (45)	343 (13.5)	345 (13.6)
#5	254 (10)	13.5 (45)	1.3 (45)	343 (13.5)	Not Performed ¹
#6	254 (10)	13.5 (45)	1.3 (45)	343 (13.5)	345 (13.6)
#7	254 (10)	13.5 (45)	1.3 (45)	343 (13.5)	345 (13.6)
#8	254 (10)	13.5 (45)	1.3 (45)	343 (13.5)	345 (13.6)
#9	254 (10)	13.5 (45)	1.2 (42.5)	335 (13.2)	Not Performed ¹
#10	254 (10)	13.5 (45)	1.3 (45)	343 (13.5)	Not Performed ¹
#11	254 (10)	13.5 (45)	1.3 (45)	343 (13.5)	345 (13.6)
#12	254 (10)	13.5 (45)	1.3 (45)	343 (13.5)	345 (13.6)

1. Since the annular space of the rod could not be cleared, the thermal sensors could not be installed and TIP testing was not performed.

As seen in Table 1, the TIP testing results agree with the expected micropile diameters. While the average diameter is useful information, it does not guarantee that necking or narrower portions of the pile are not present. As seen in Figure 7 and Figure 10, the diameter determined by TIP testing can vary with depth. TIP testing allows for a more detailed view of the pile profile and can alert the project team to potential issues

with installation methods or the in-situ soil profile. The figures displaying the results of TIP testing for each of the tested micropiles are included in the Appendix.

While this method of verification cannot replace full time inspection by a qualified inspector or load testing, it can be performed relatively easily, and is another valuable and innovative method to determine proper pile installation.

Since this was a relatively small project, we did not physically pull any of the piles to verify the results of the TIP testing with the actual micropile diameters. To further evaluate TIP testing methods with micropiles, Terracon is planning on working in the future to install test piles at a coastal Charleston site and then performing TIP testing, static load tests, and actually pulling the test piles to compare TIP results to the actual pile.

REFERENCES

- 2015 International Building Code. Country Club Hills, Ill: ICC, 2014. Print.
- AASHTO LRFD Bridge Design Specifications. Washington, D.C: American Association of State Highway and Transportation Officials, 2014. Print.
- ASTM D 6760-08, "Standard Test Method for Integrity Testing of Concrete Deep Foundations by Ultrasonic Crosshole Testing", American Society for Testing and Materials, Philadelphia, PA, Construction Vol 4:08
- ASTM D 7949-14, "Standard Test Methods for Thermal Integrity Profiling of Concrete Deep Foundations", American Society for Testing and Materials, Philadelphia, PA, Construction Vol 4:09
- Piscsalko, P.E., George, "Thermal Integrity Profiler (TIP)", Pile Dynamics, Inc., May, 2016. Print.

Appendix

Pile 1 - Temperature vs. Depth

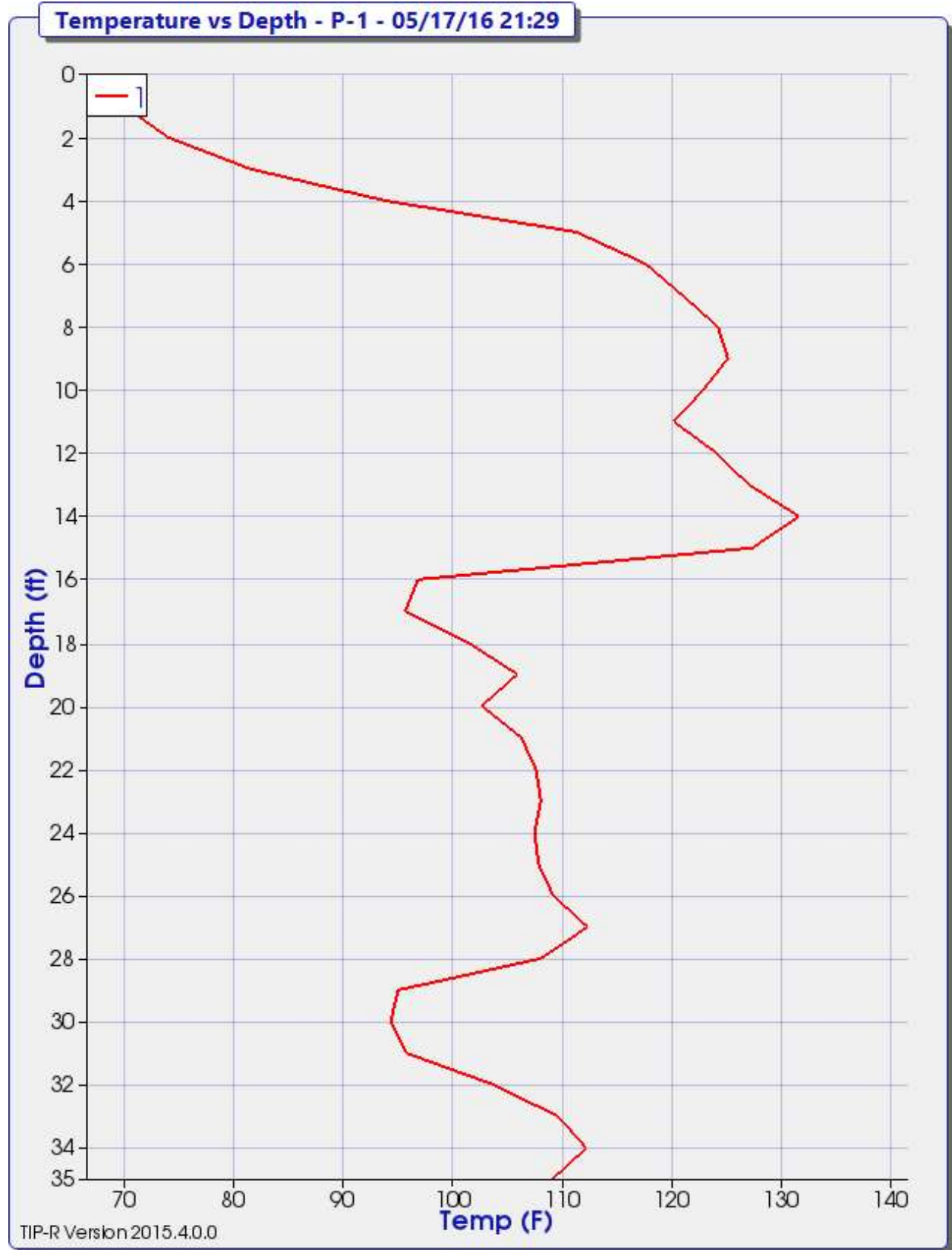

Pile 1 – Radius vs. Depth

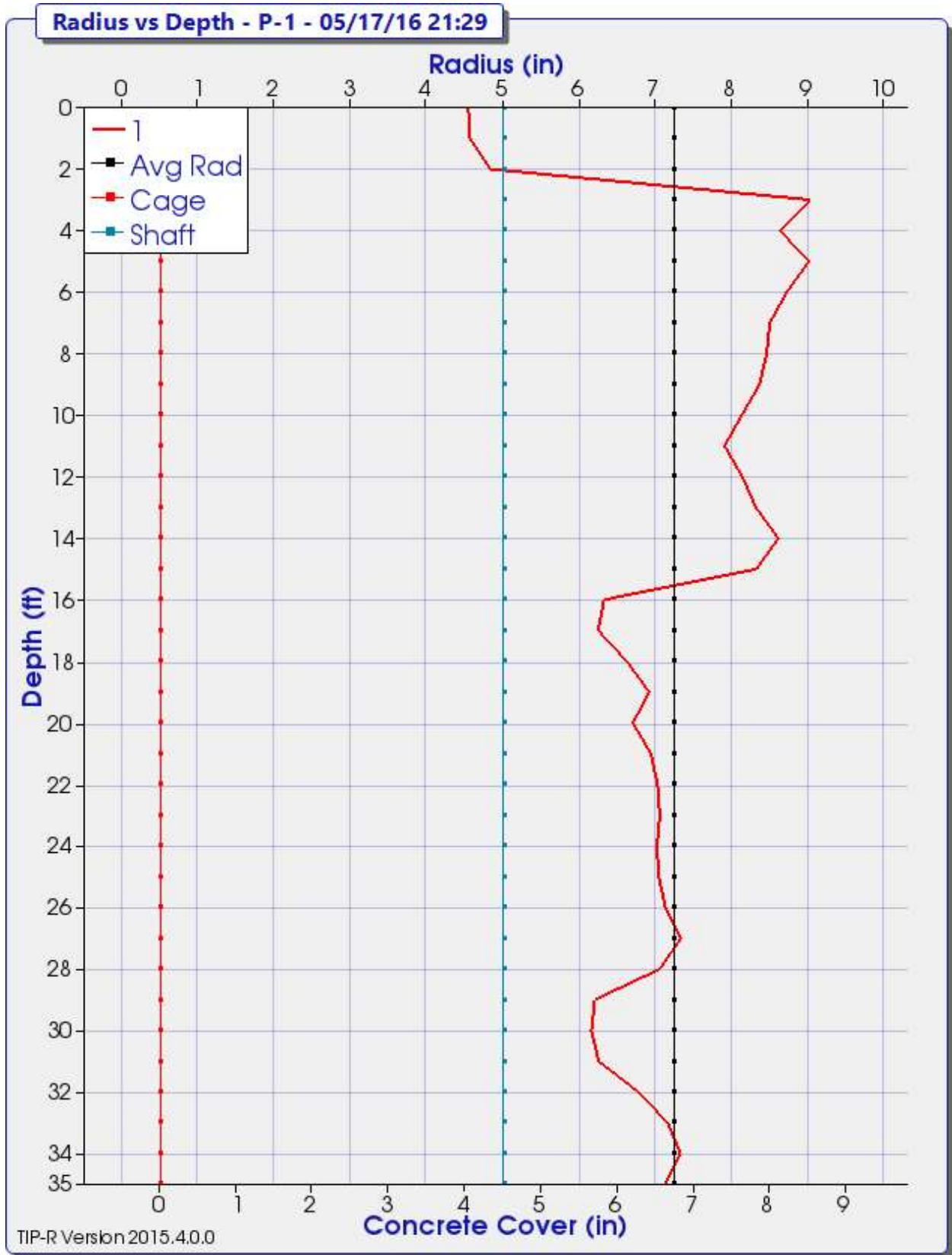

Pile 1 – 3D Cage View

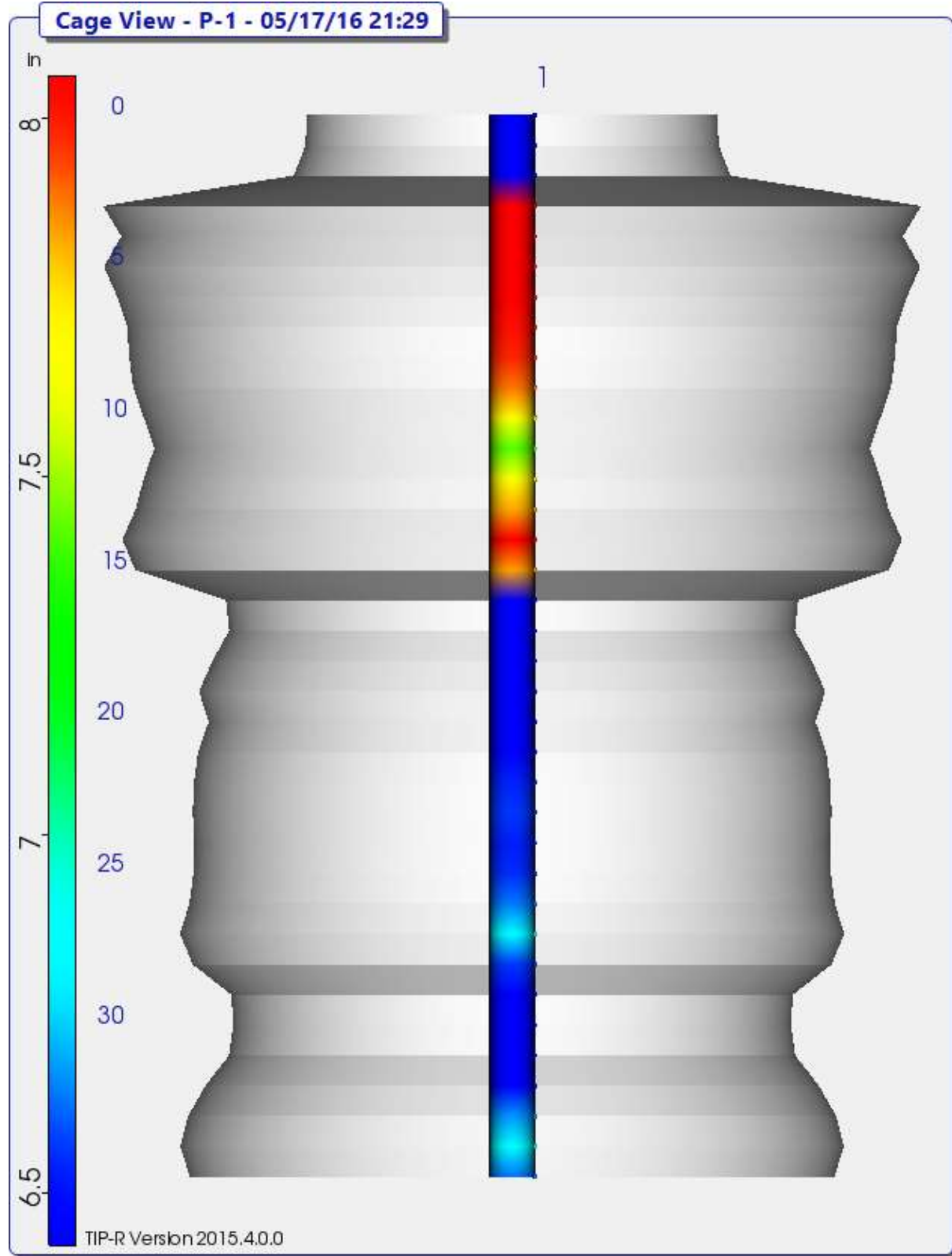

Pile 2 – Temperature vs. Depth

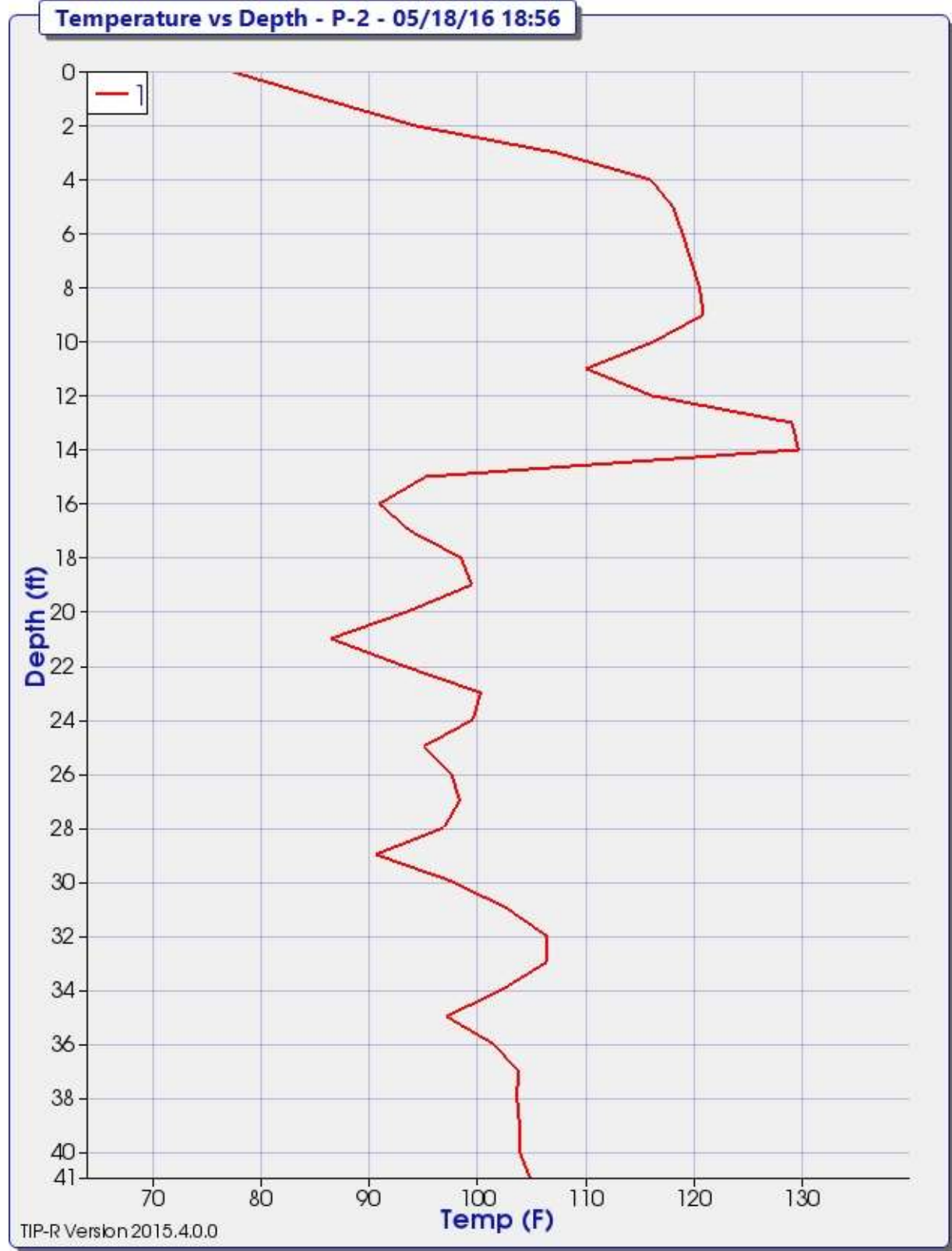

Pile 2 – Radius vs. Depth

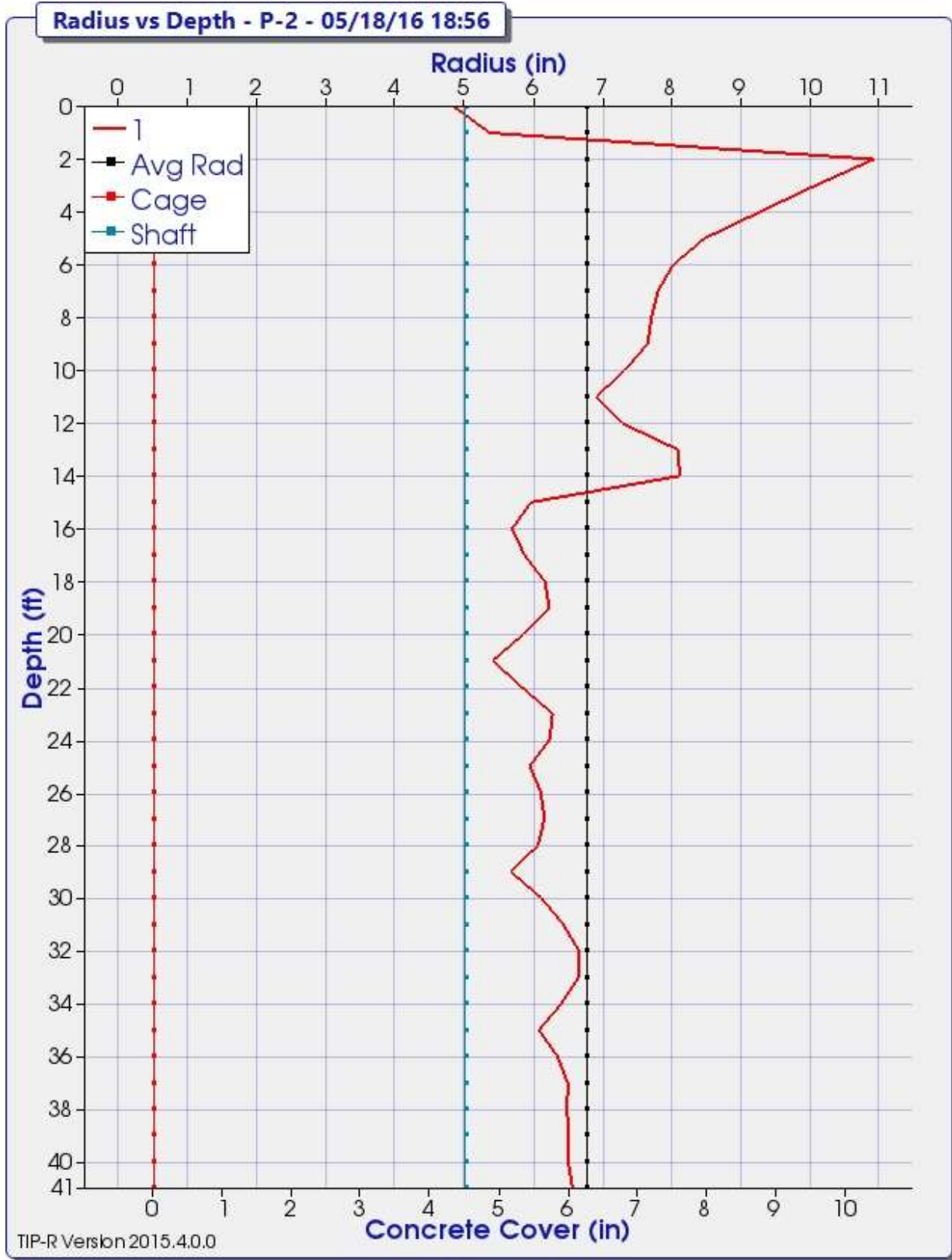

Pile 2 – 3D Cage View

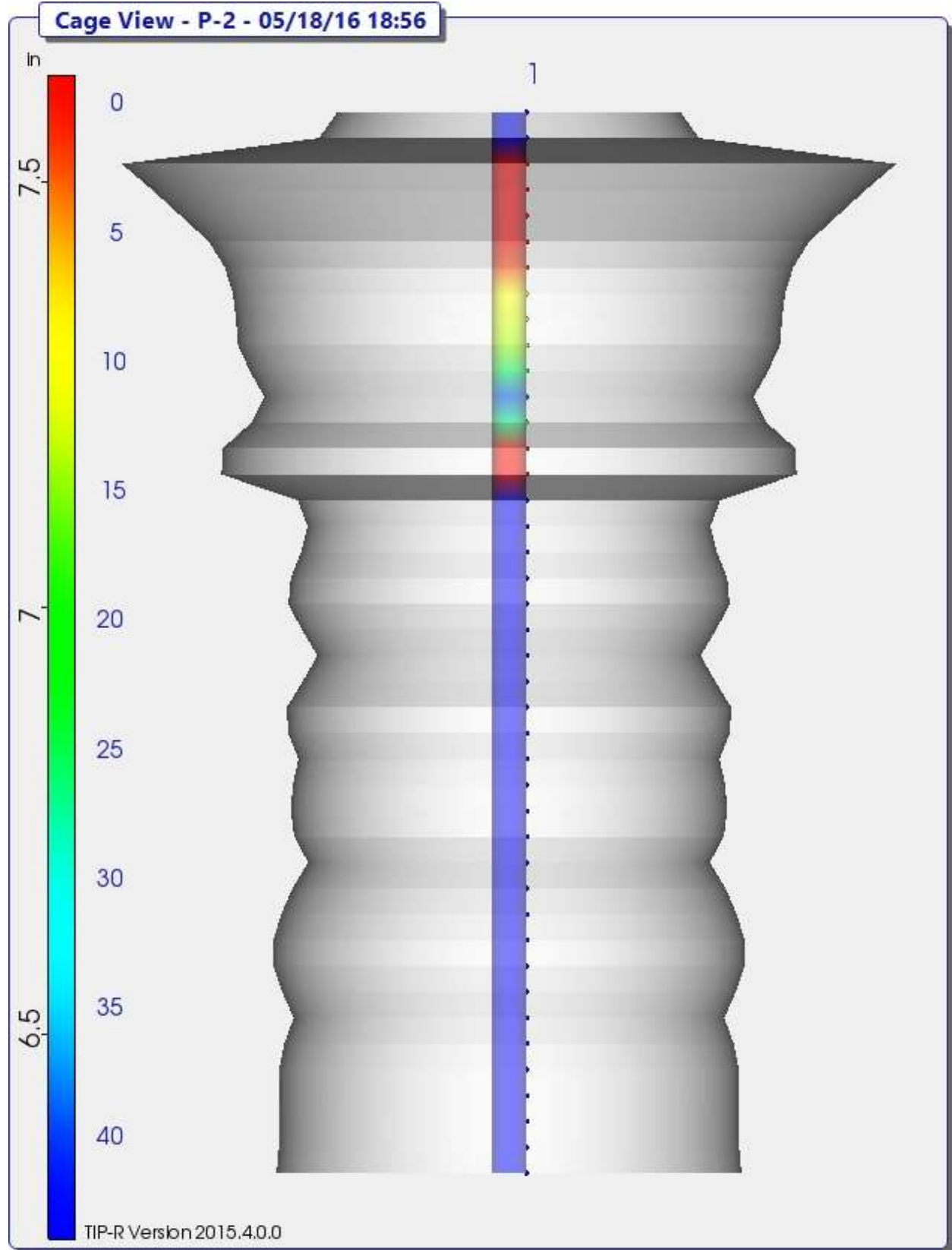

Pile 3 – Temperature vs. Depth

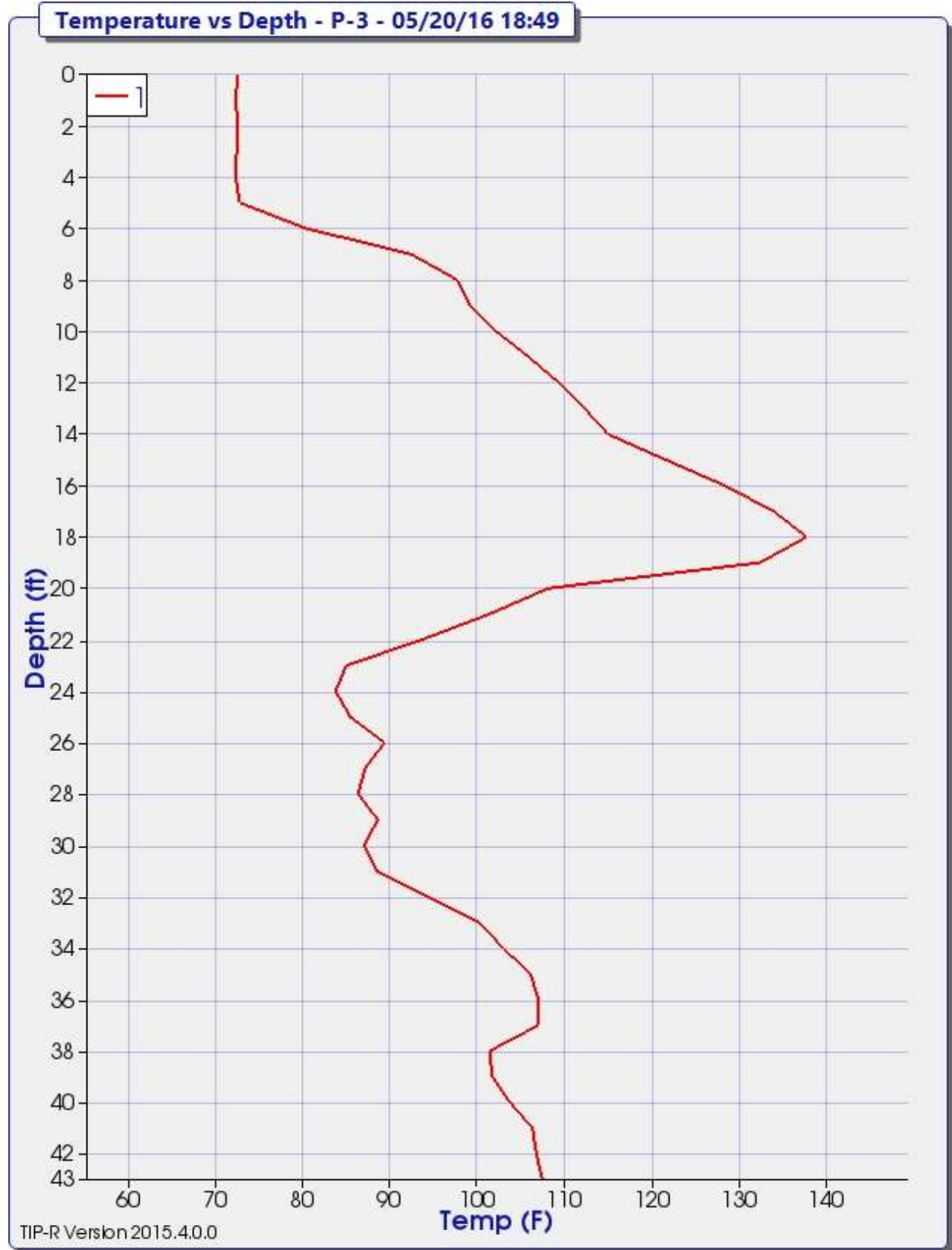

Pile 3 – Radius vs. Depth

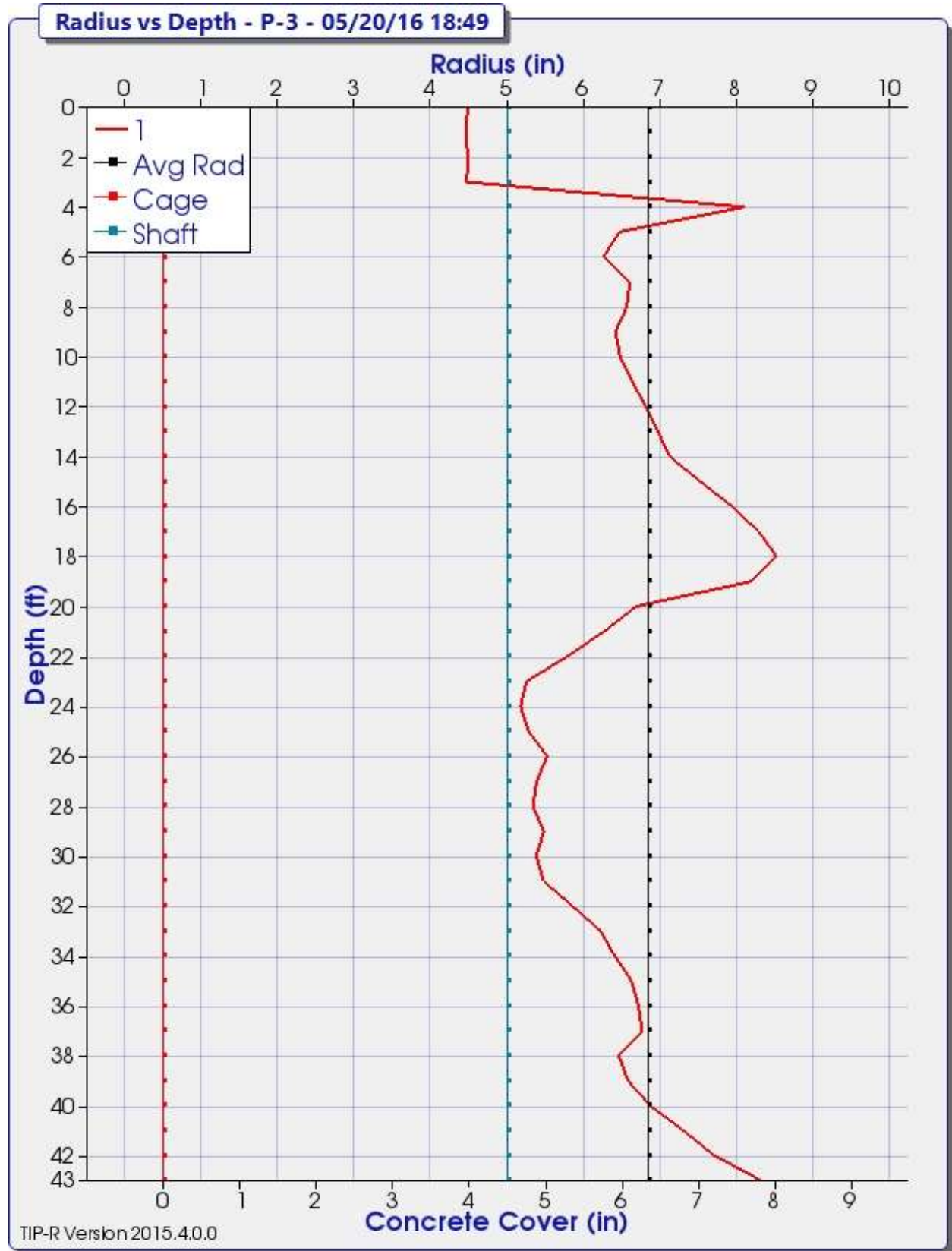

Pile 3 – 3D Cage View

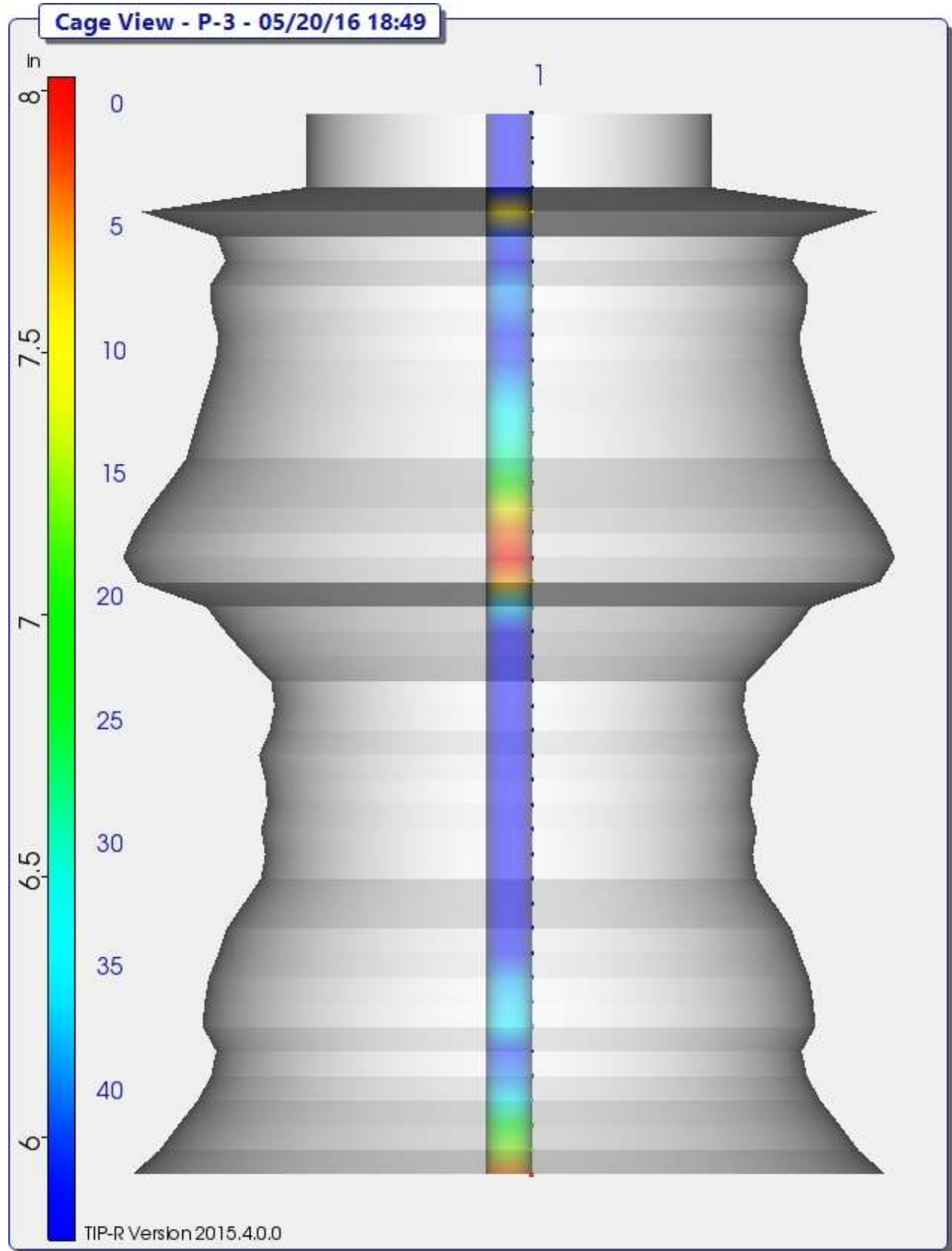

Pile 4 – Temperature vs. Depth

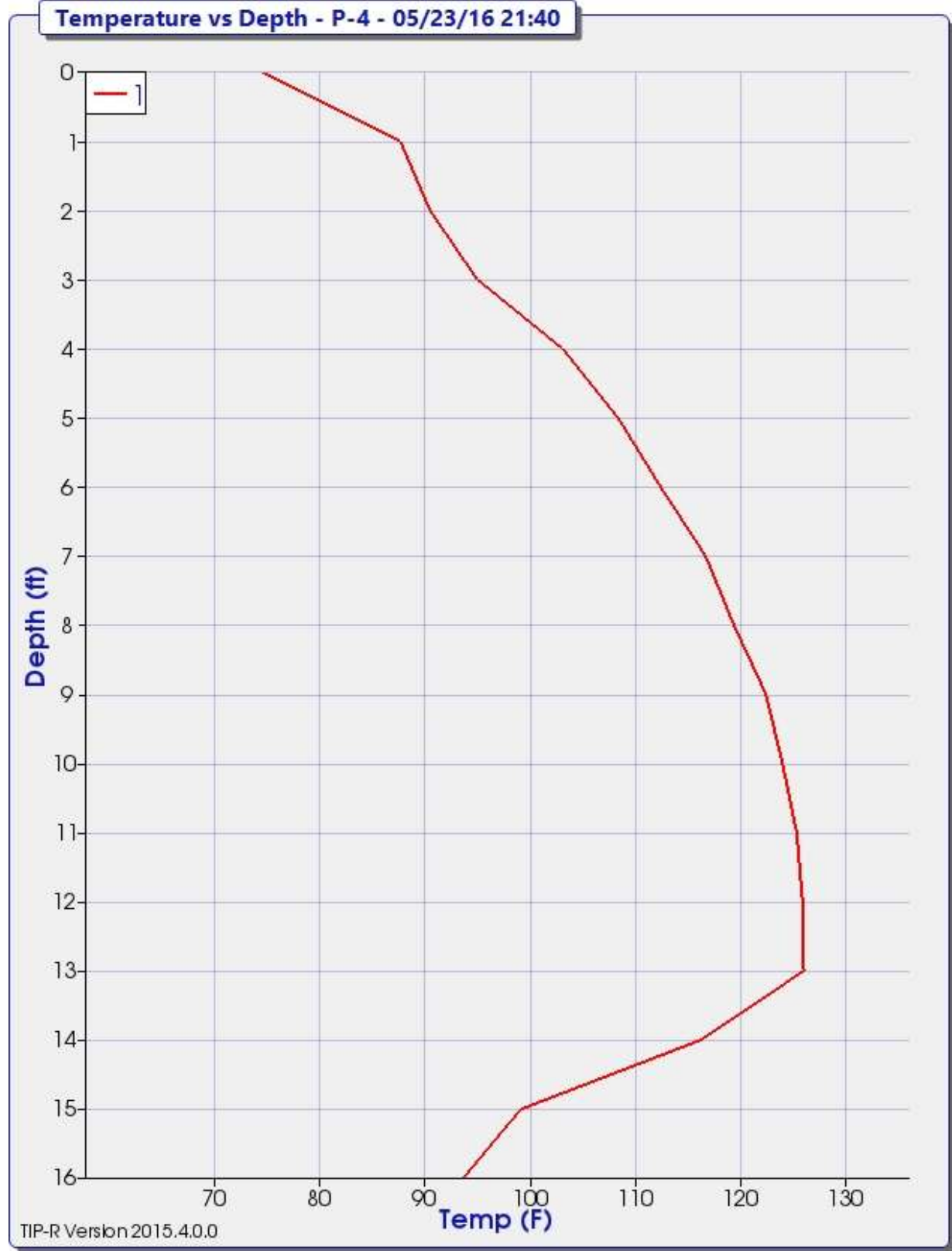

Pile 4 – Radius vs. Depth

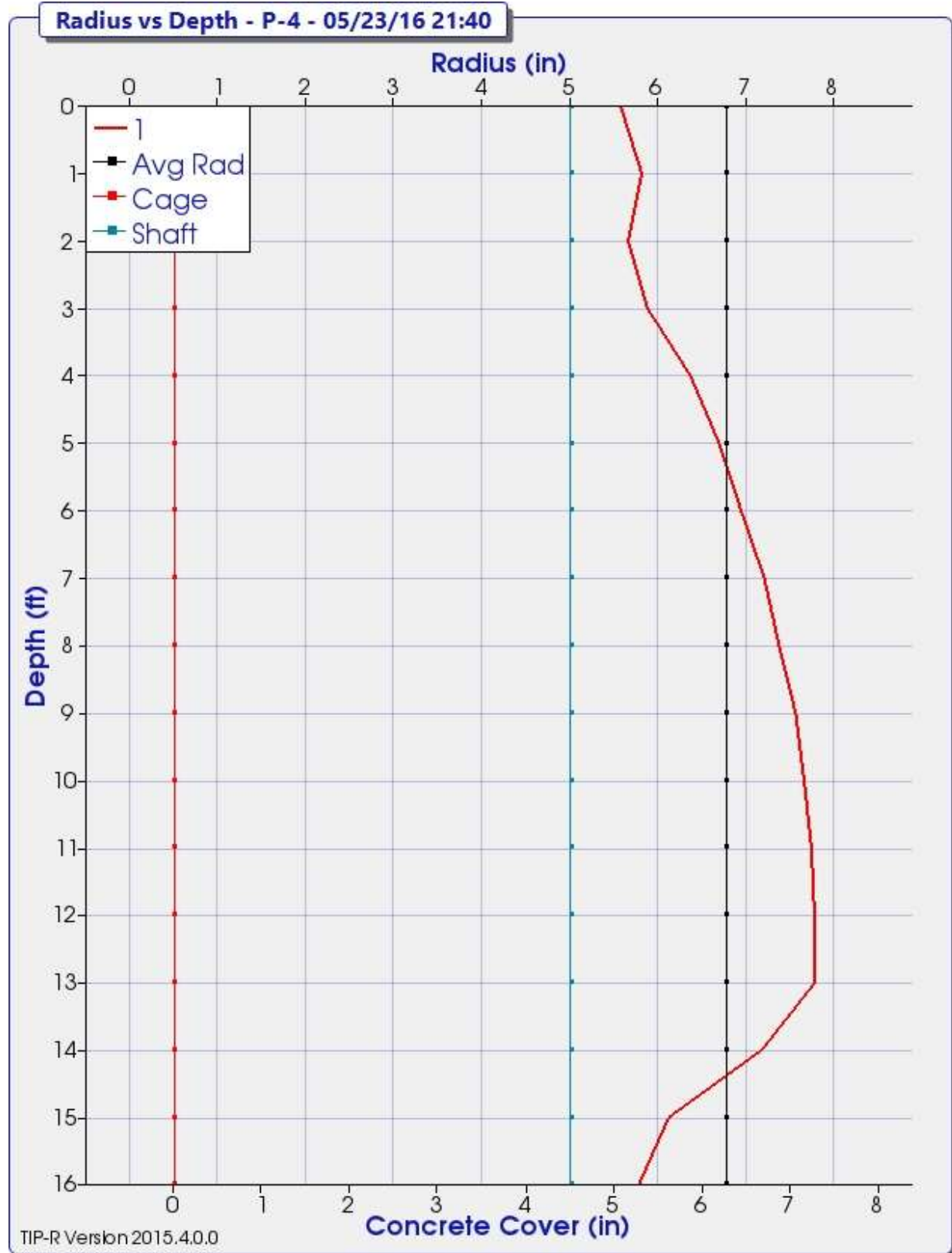

Pile 4 – 3D Cage View

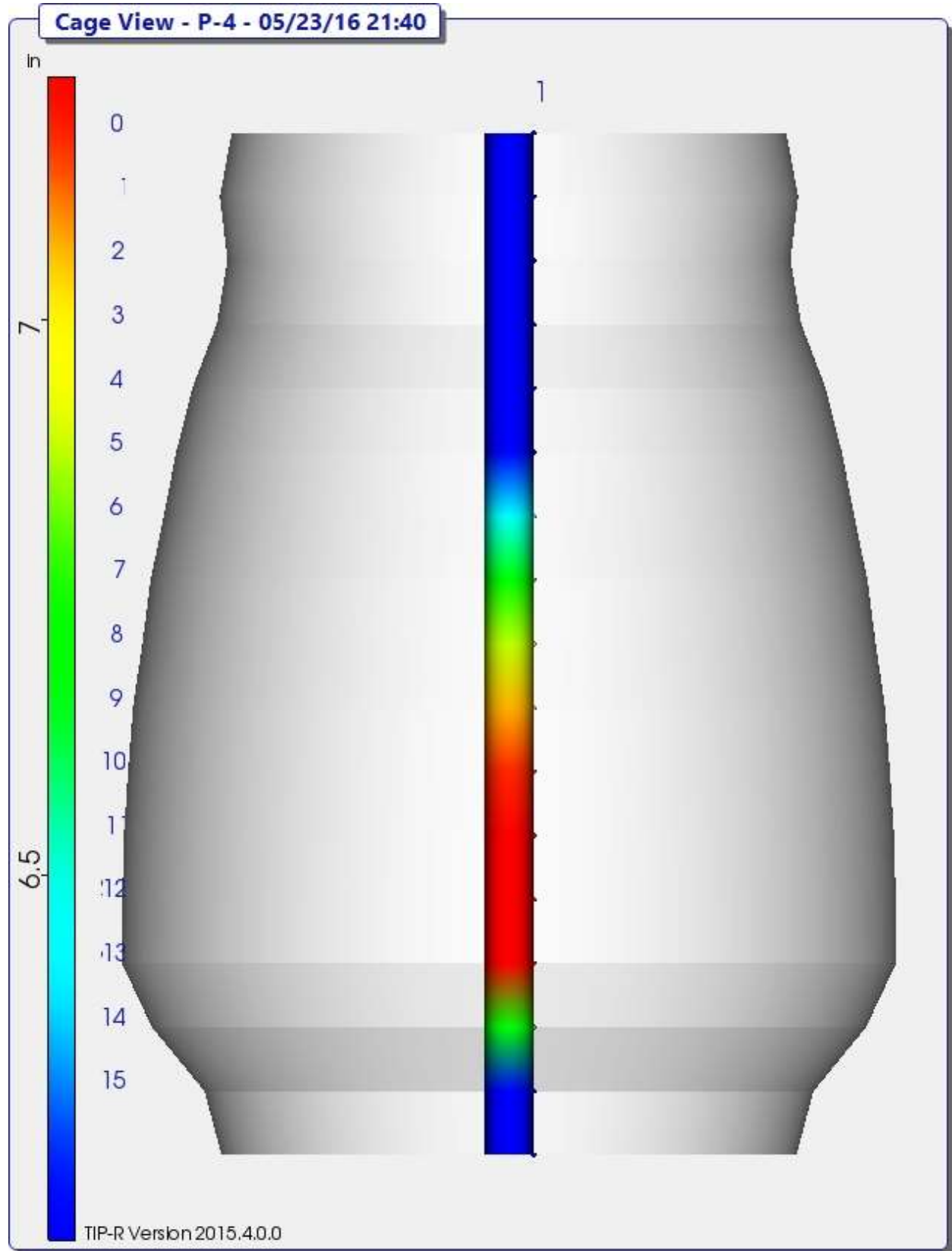

Pile 6 – Temperature vs. Depth



Pile 6 – Radius vs. Depth

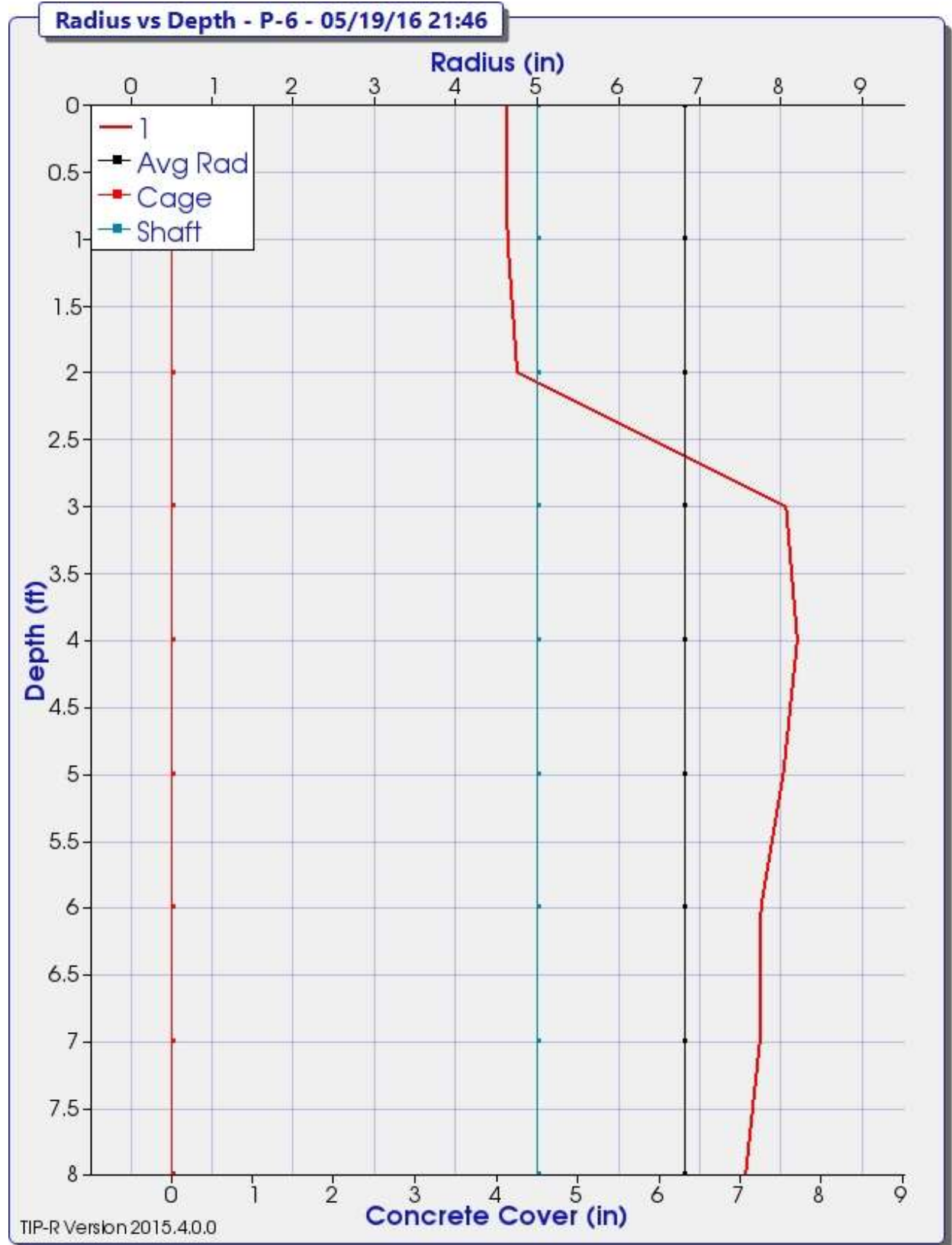

Pile 6 – 3D Cage View

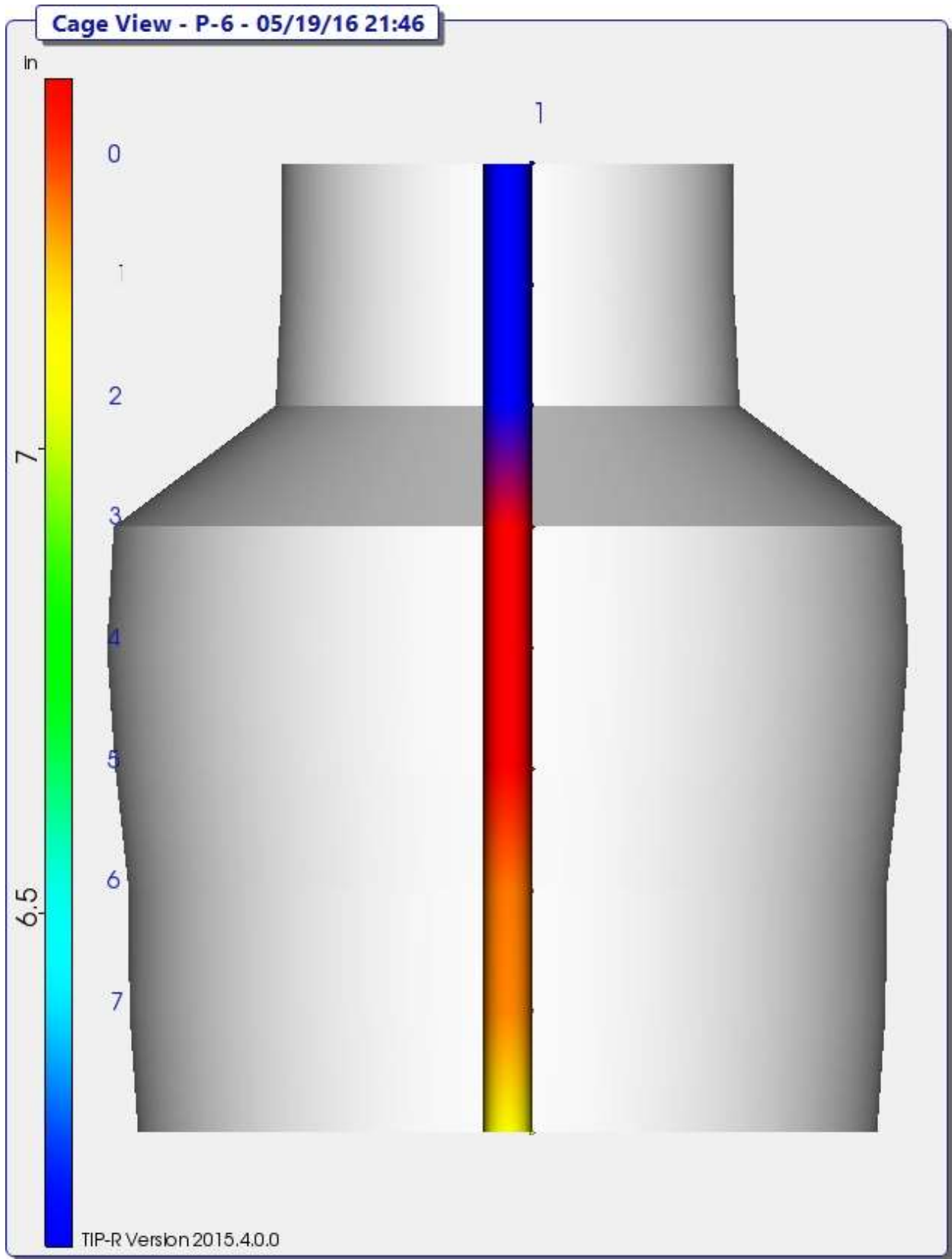

Pile 7 – Temperature vs. Depth

Temperature vs Depth - P-7 - 05/23/16 19:13

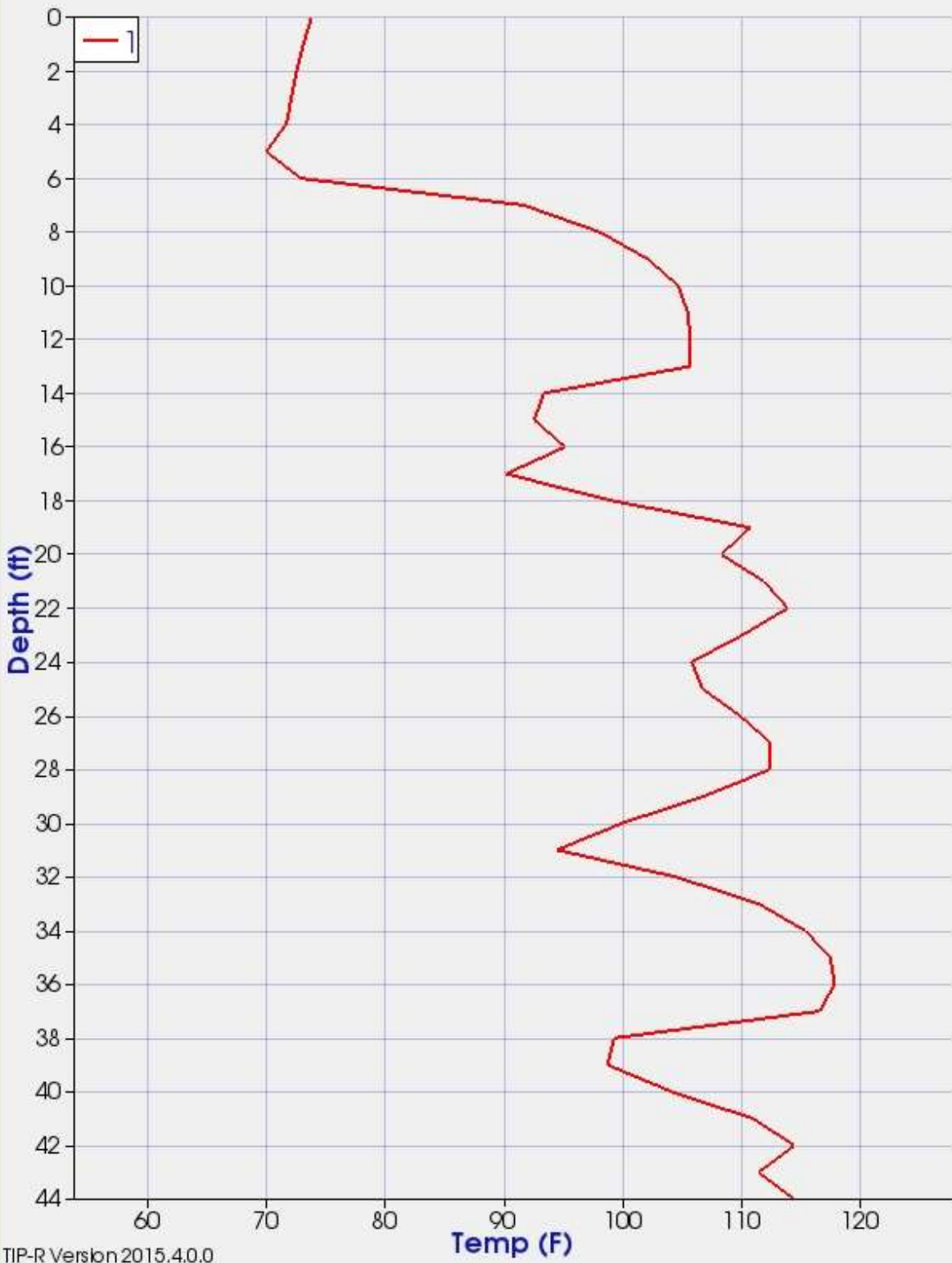

TIP-R Version 2015.4.0.0

Pile 7 – Radius vs. Depth

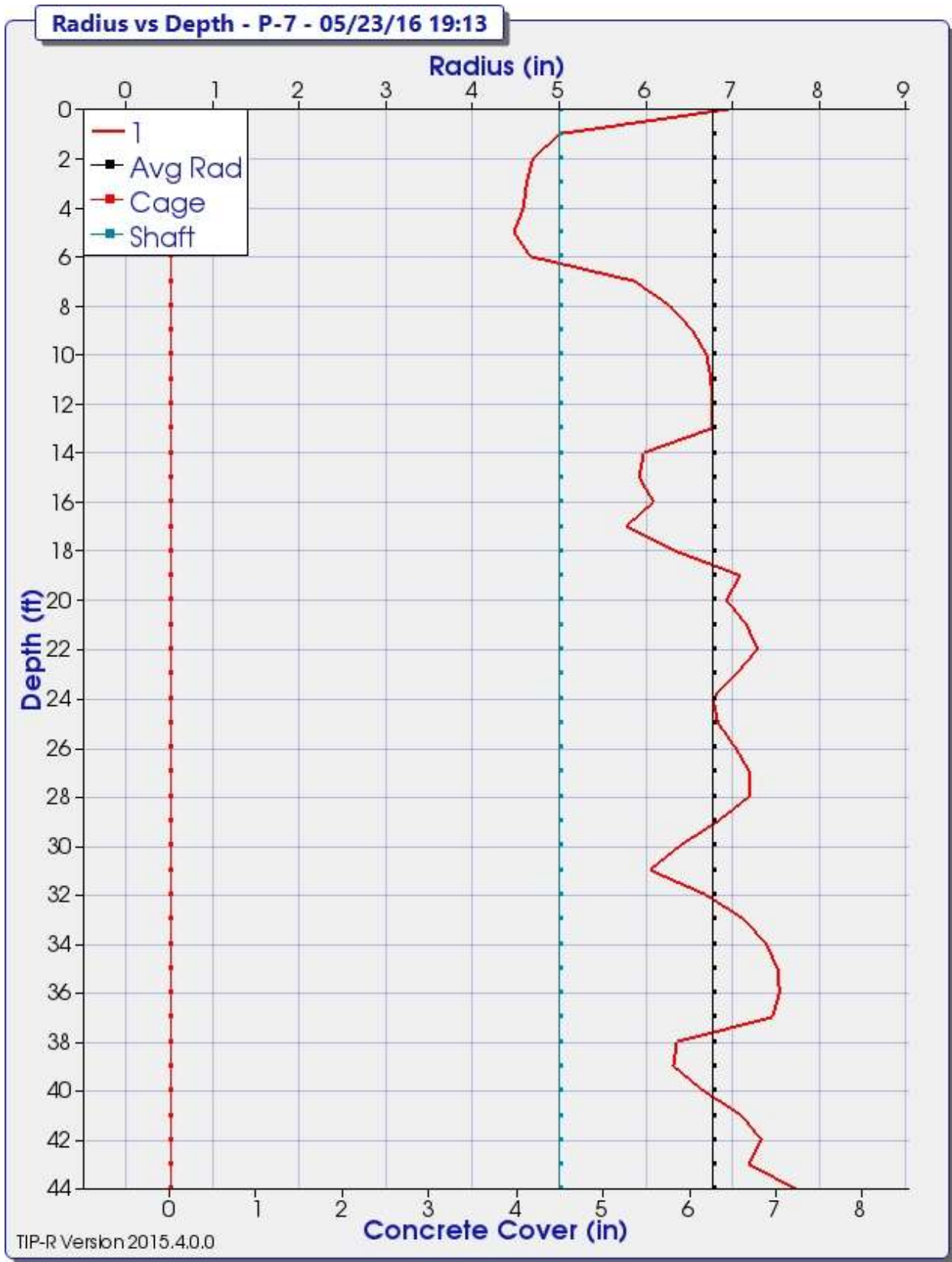

Pile 7 – 3D Cage View

Cage View - P-7 - 05/23/16 19:13

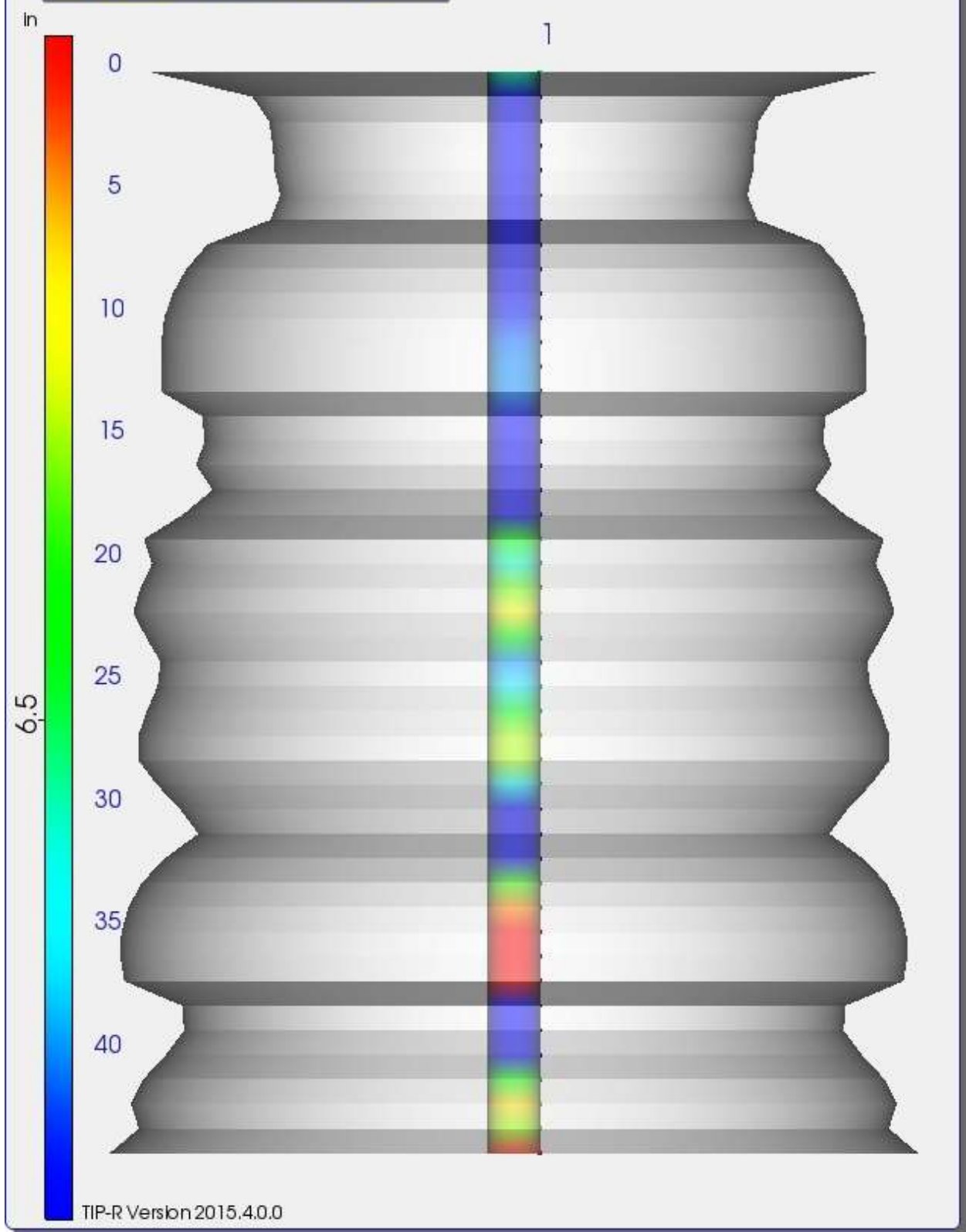

Pile 8 – Temperature vs. Depth



Pile 8 – Radius vs. Depth



Pile 8 – 3D Cage View

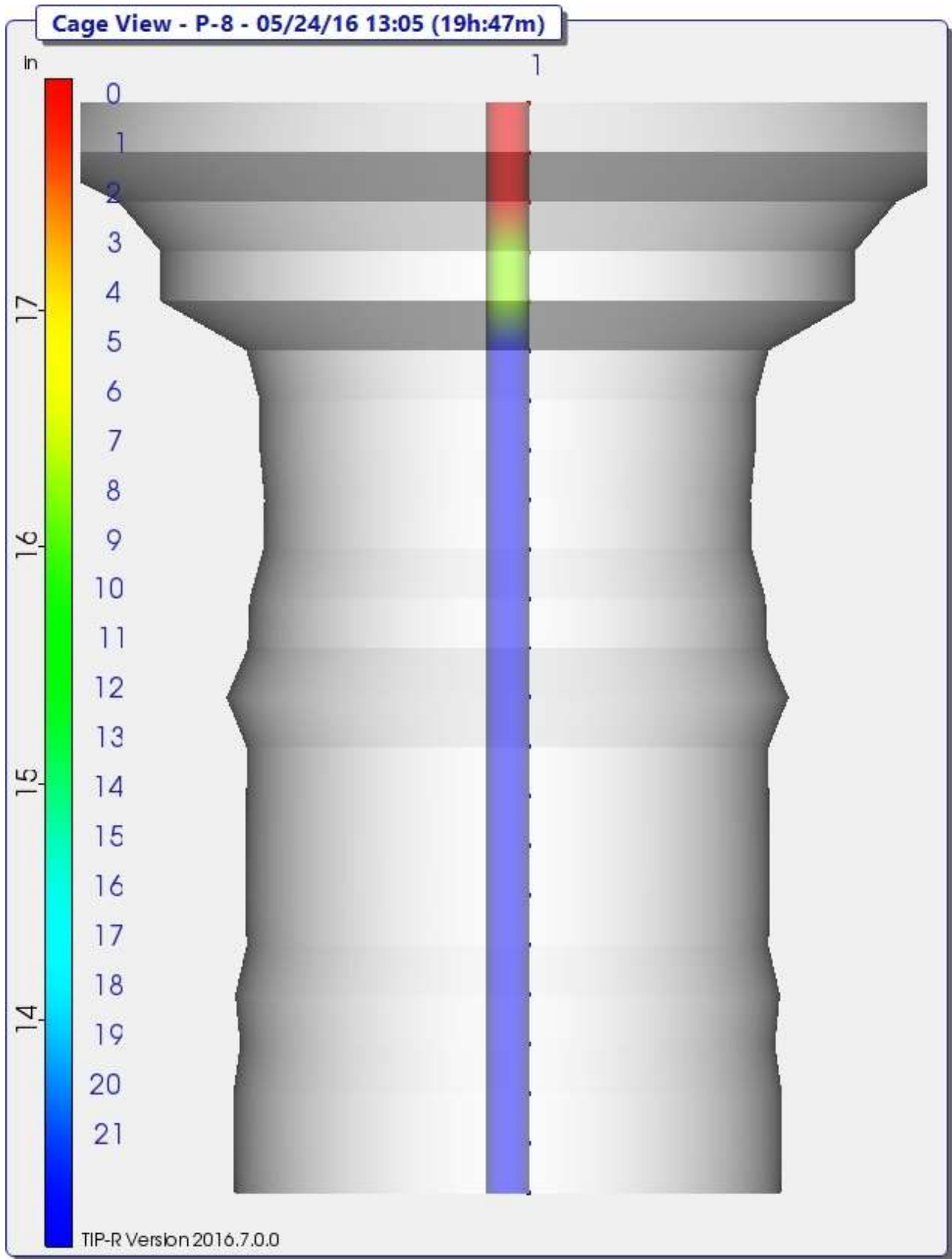

Pile 11 – Temperature vs. Depth

Temperature vs Depth - P-11 - 05/19/16 18:13

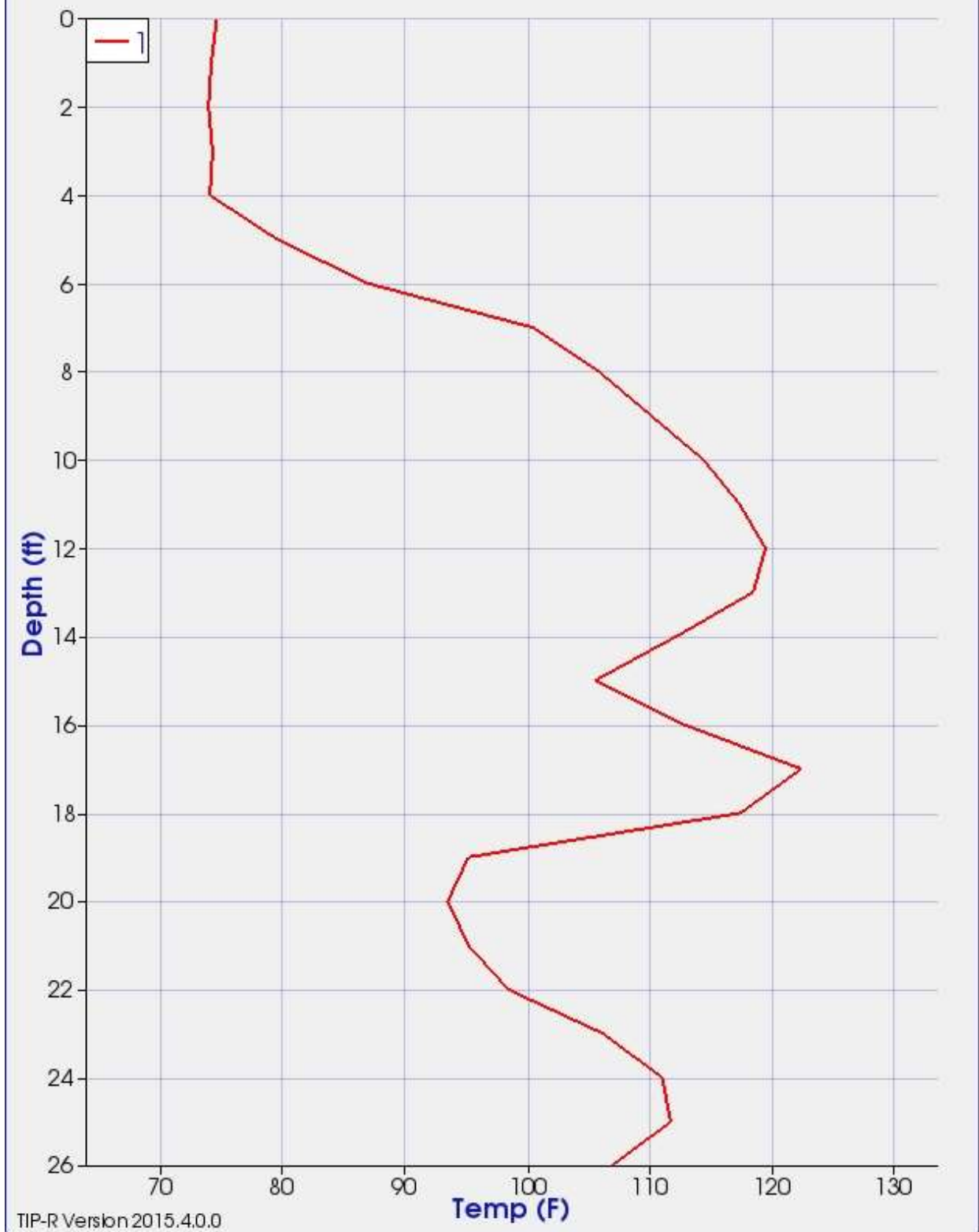

Pile 11 – Radius vs. Depth

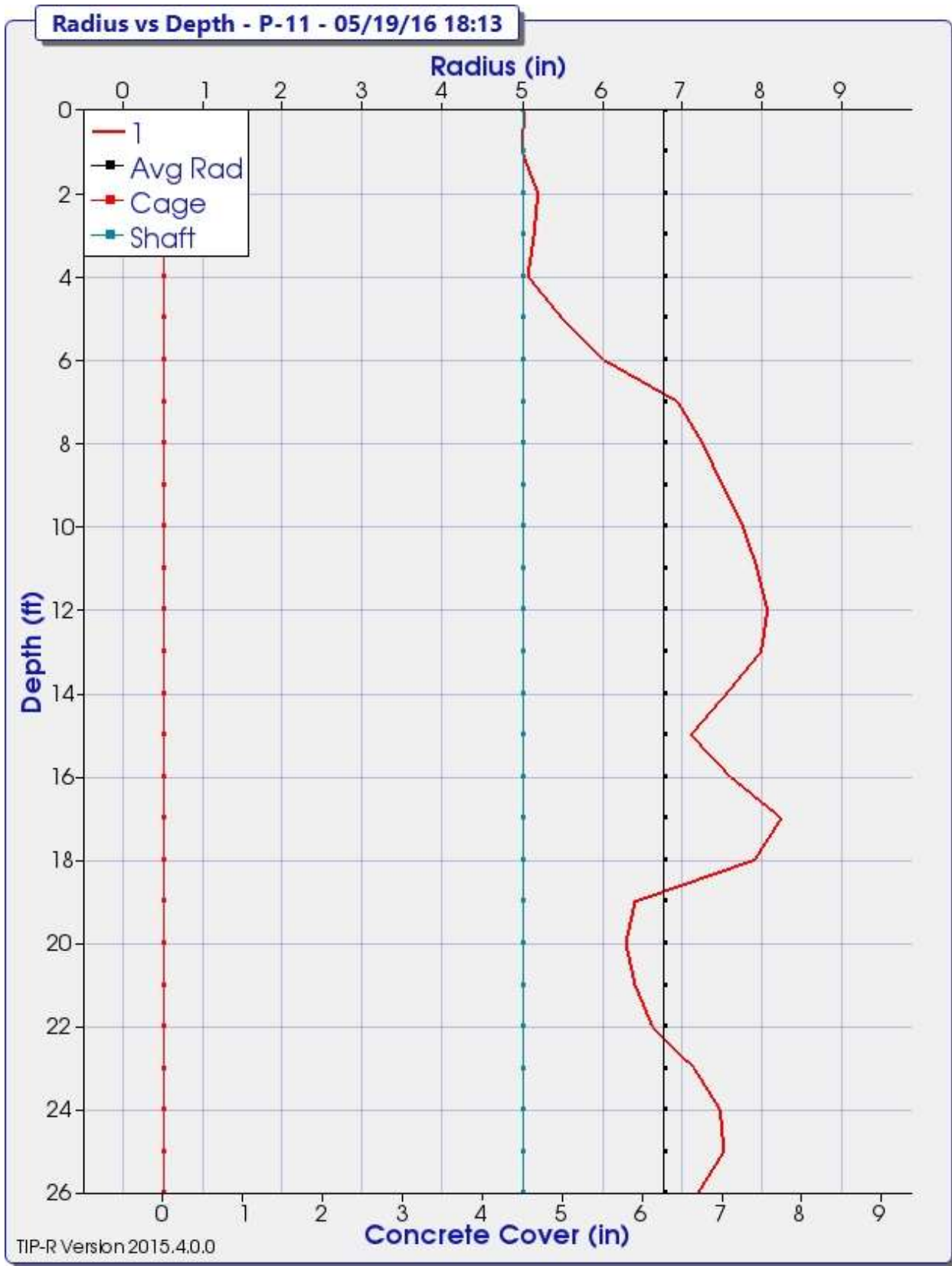

Pile 11 – 3D Cage View

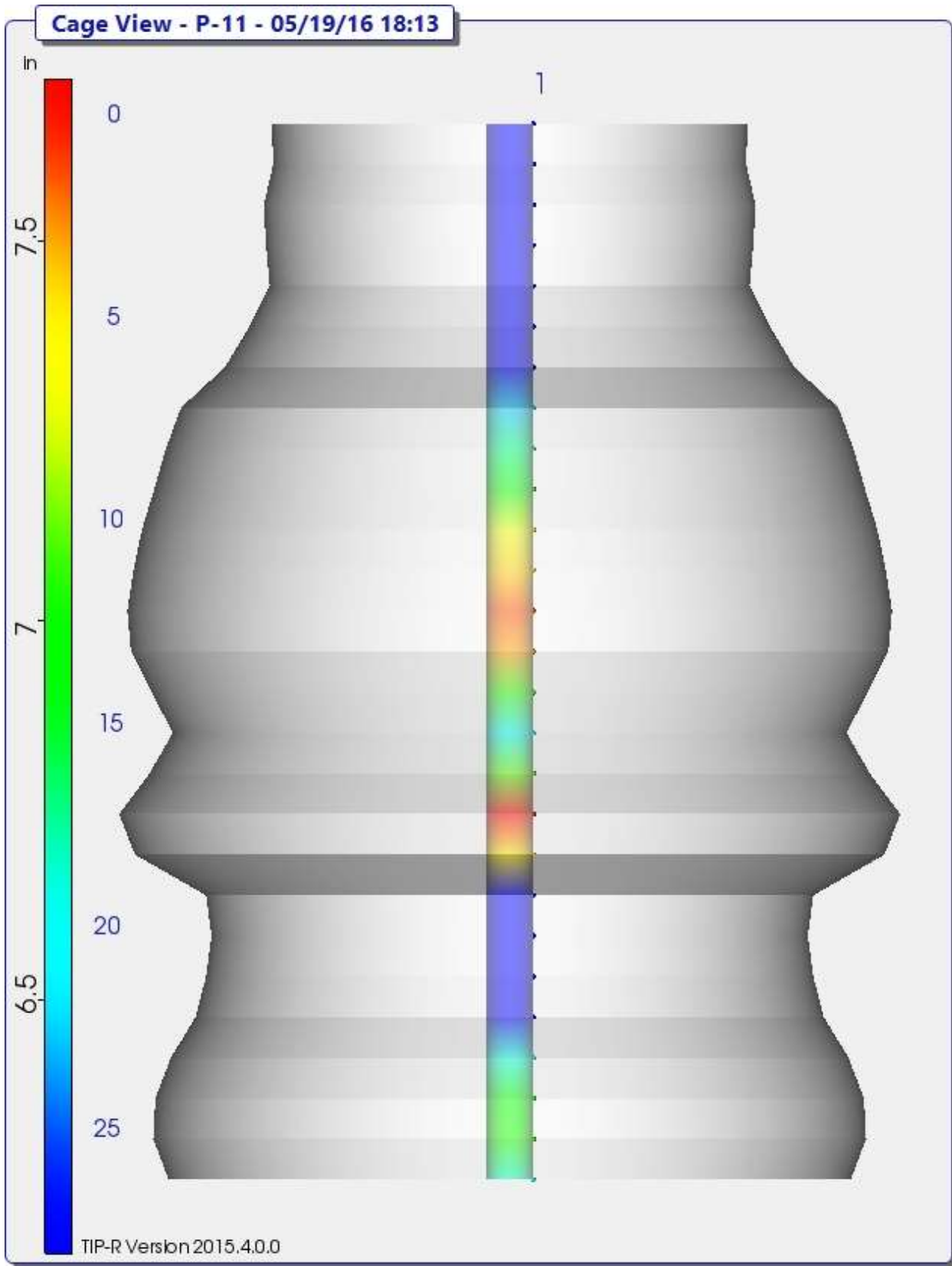

Pile 12 – Temperature vs. Depth

Temperature vs Depth - P-12 - 05/20/16 21:43



Pile 12 – Radius vs. Depth

Radius vs Depth - P-12 - 05/20/16 21:43

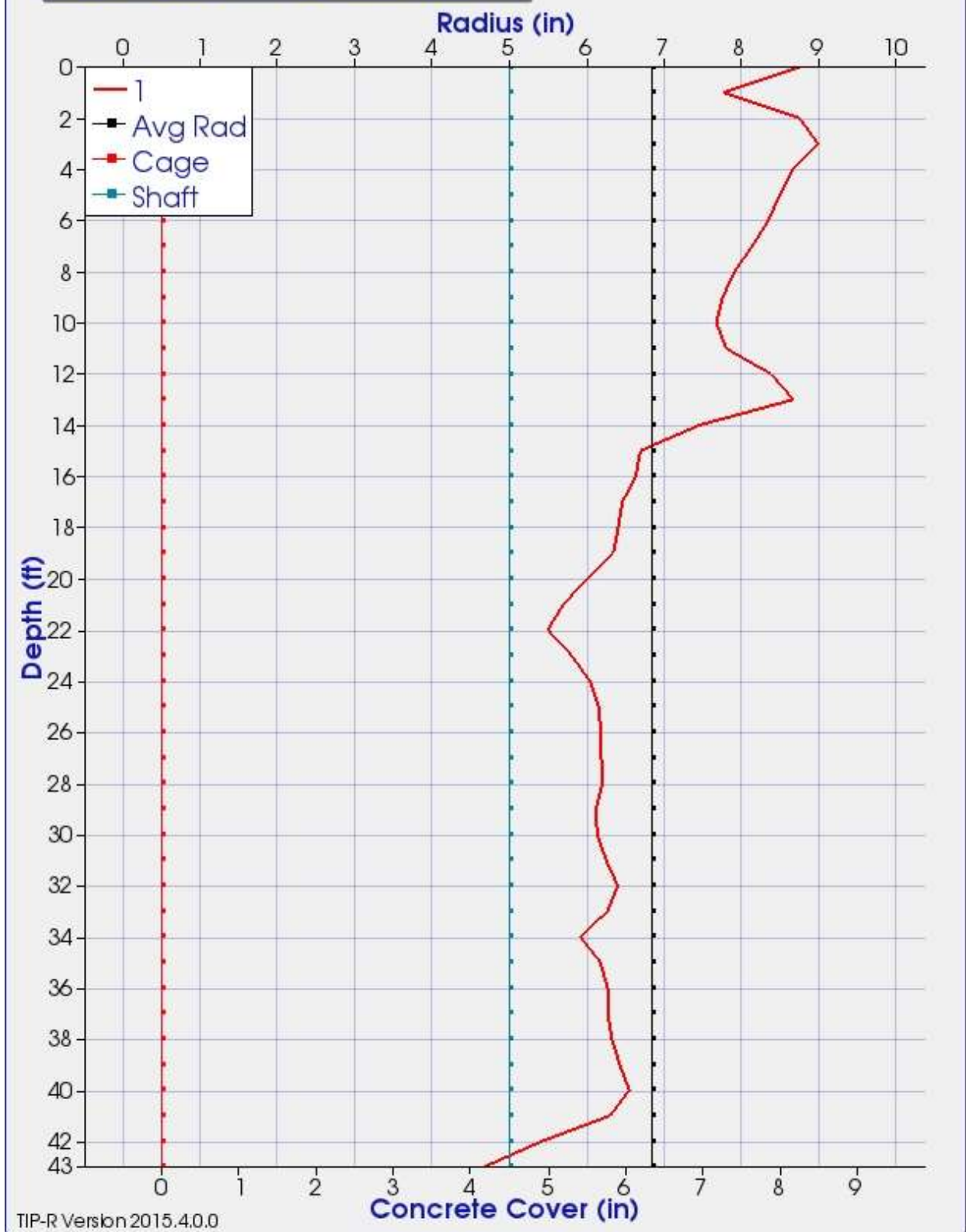

TIP-R Version 2015.4.0.0

Pile 12 – 3D Cage View

Cage View - P-12 - 05/20/16 21:43

